

Kwiksol

SOLAR WATER HEATING SYSTEMS



**EFFICIENT USE OF NATURAL
SOLAR ENERGY FROM THE**

SUN

REV0421

INSTRUCTION, INSTALLATION & WARRANTY MANUAL

INDEX

<i>A. INSTALLER COMPETENCY</i>	<i>3</i>
<i>B. COMPONENTS</i>	
<i>C. UNDERSTANDING THE THERMOSYPHON - CLOSE COUPLED CIRCULATION METHOD</i>	<i>3</i>
<i>D. UNDERSTANDING THE SPLIT PUMPED CIRCULATION METHOD</i>	<i>3</i>
<i>E. SOLAR SYSTEM TYPES</i>	<i>4</i>
<i>F. FEATURES OF SOLAR FLAT PLATE COLLECTOR PANEL</i>	<i>6</i>
<i>G. FEATURES OF THE SOLAR VACUUM TUBES</i>	<i>7</i>
<i>H. ROOF LOCATION OF A SOLAR SYSTEM</i>	<i>7</i>
<i>I. INSTALLATION OF A SOLAR WATER HEATER SYSTEM</i>	<i>9</i>
<i>J. FILLING A SOLAR SYSTEM</i>	<i>17</i>
<i>K. DRAINING AN INDIRECT SOLAR SYSTEM</i>	<i>18</i>
<i>L. GENERAL MAINTENANCE OF THE SOLAR SYSTEM - FOR THE HOMEOWNER</i>	<i>18</i>
<i>M. SAFETY PRECAUTIONS & EMERGENCY SHUTDOWN PROCEDURE - FOR THE HOMEOWNER</i>	<i>19</i>
<i>N. WARRANTIES - FOR THE HOMEOWNER</i>	<i>19</i>
<i>O. PERTINENT INFORMATION - FOR THE HOMEOWNER (TO BE COMPLETED BY THE INSTALLER)</i>	<i>23</i>
<i>P. PERTINENT INFORMATION FOR Electrolux SA (Pty) Ltd TO VALIDATE THE WARRANTY</i>	<i>25</i>

A. INSTALLER COMPETENCY

The installer must be an accredited installer, qualified in plumbing and knowledgeable with **SANS 10106** Solar Water Heater and **SANS 10254** Electric Water Heater Specifications.

B. COMPONENTS

All components must be SANS approved where applicable.

C. UNDERSTANDING THE THERMOSYPHON – CLOSE COUPLED CIRCULATION METHOD

The compulsory requirement for a thermosyphon circulation method is that the solar water heater is installed in a position higher than the solar flat plate collector panel/s or manifold of the solar vacuum tubes. The circulation flow occurs without any moving parts or auxiliary electrical energy input into the system.

This system operates according to the basic principles of physics: a liquid if heated, becomes less dense and rises upwards. The heated transfer fluid, either water (direct system) or propylene glycol (indirect system) in the solar flat plate collector panel/s or manifold of the solar vacuum tubes, rises up into the solar water heater and transmits heat to it, while the cold transfer fluid travels back down to the solar flat plate collector panel/s or manifold of the solar vacuum tubes and the process is repeated.

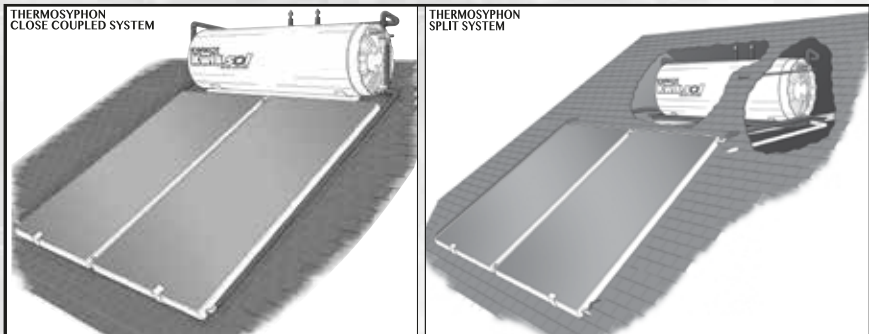

When there is no solar radiation, the transfer fluid in the solar flat plate collector panel/s becomes heavy, blocks the circulation and prevents the heat accumulated in the solar water heater from being dispersed.

D. UNDERSTANDING THE SPLIT PUMPED CIRCULATION METHOD

It is not always possible or convenient to install the solar water heater in a higher position than the solar flat plate collector panel/s or manifold of the vacuum tubes (thermosyphon circulation method), so the pumped circulation method has to be used.

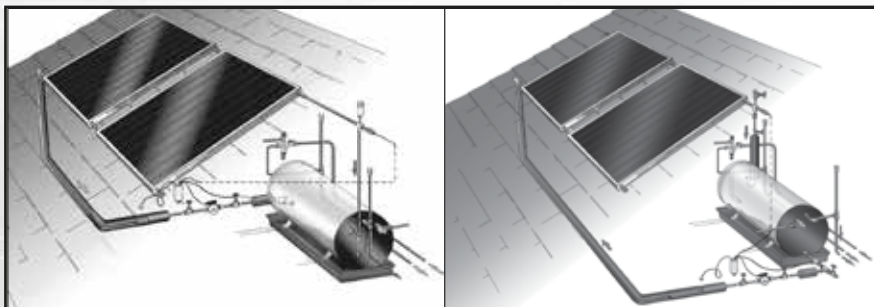

A circulating pump either electrical or a 12V Pump with a PV Panel can be used. The control unit using two sensors constantly monitors the temperature of the solar flat plate collector panel/s or solar vacuum tubes and the solar water heater, powering the circulation pump only when the water (direct system) or propylene glycol (indirect system) in the solar flat plate collector panel/s or solar vacuum tubes is hotter than the water in the solar water heater.

When the temperature difference is less than the set point during the working process of the circulating pump, the pump will stop. When the temperature of the water in the solar water heater reaches the highest set point, the monitor will stop the circulating pump.

The electrical thermostat and element will automatically maintain the water temperature of the upper part of the solar water. The set temperature on the thermostat must be lower than the maximum temperature attainable on the solar flat plate collector panel/s or manifold of the solar vacuum tubes.

Pumps must be installed in accordance with the manufacturers instructions with ease of access for maintenance/repair.

E. SOLAR SYSTEM TYPES

1. Direct Frost Free System – Close Coupled and Split System (Thermosyphon and Pumped Circulation Methods)

The Direct system with solar flat plate collector panels is used in areas where the ambient temperature never falls below 5°C and the water quality is good (less than 600ppm total dissolved solids/minerals).

The water to be used from the solar water heater circulates through the solar flat plate collector panel/s, transferring solar energy into the storage tank. The solar water heater is fitted with a thermostat and element in the event the solar energy is not strong enough to heat the water to the required set temperature i.e. on overcast days and in the evening.

The Direct system can be installed as a close coupled system (thermosyphon circulation method) or as a split system (thermosyphon or pumped circulation methods).

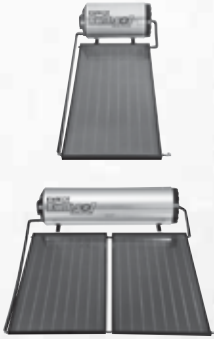

Number and Size of Solar Flat Plate Collector Panel to Use

SOLAR WATER HEATER	NUMBER OF PANELS	ENERGY TRANSFER LIQUID	HEAT LOSS AT NIGHT
150lt	1 x 2m ²	Water	9,84%
200lt	1 x 2.5m ²	Water	12,44%
300lt	2 x 2m ²	Water	8,77%

2. Direct Frost Resistant System – Close Coupled System (Thermosyphon Circulation Method)

The Direct system with solar vacuum tubes is used in areas where the ambient temperature falls below 5°C and the water quality is good (less than 600ppm total dissolved solids/minerals).

The water to be used from the solar water heater circulates through the manifold of the solar vacuum tubes, transferring solar energy into the storage tank. The solar water heater is fitted with a thermostat and element in the event the solar energy is not strong enough to heat the water to the required set temperature i.e. on overcast days and in the evening. A pipe set is supplied with silicone inserts to connect the solar water heater to the manifold of the solar vacuum tubes manifold, in order to prevent freezing. The manifold is insulated and resistant against freezing.



Copper tube with R1 Lagging and Silicone Insert



Number of Solar Vacuum Tubes to Use

SOLAR WATER HEATER	NUMBER OF TUBES	ENERGY TRANSFER LIQUID	HEAT LOSS AT NIGHT
100lt	12 (2 x 6)	Water	16,05%
150lt	16 (1 x 6 + 1 x 10)	Water	17,53%
200lt	20 (2x10)	Water	12,60%
300lt	32 (2 x 6 + 2 x 10)	Water	9,1%

3. Indirect Frost Resistant System - Close Coupled and Split System (Thermosyphon and Pumped Circulation Methods)

The Indirect system is used in areas where frost occurs, where the ambient temperature fall below 5°C and the water quality is poor (more than 600ppm Total Dissolved Solids/Minerals).

The water to be used from the solar water heater does not circulate through the solar flat plate collector panel/s, but remains in the solar water heater and is heated through a heat exchanger around the inner vessel. Propylene glycol is used to circulate through the solar flat plate collector panel/s, transferring solar energy into the heat exchanger and in turn heating the water stored in the solar water heater.

The solar water heater is fitted with a thermostat and element in the event the solar energy is not strong enough to heat the water to the required set temperature i.e. on overcast days and in the evening.

The Indirect system can be installed as a close coupled system (thermosyphon circulation method) or as a split system (thermosyphon or pumped circulation methods).

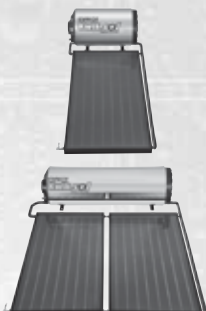

Number and Size of Solar Flat Plate Collector Panel to Use

SOLAR WATER HEATER	NUMBER OF PANELS	ENERGY TRANSFER LIQUID	HEAT LOSS AT NIGHT
150lt	1 x 2m ²	Propylene Glycol	9,84%
200lt	1 x 2.5m ²	Propylene Glycol	13,34%
300lt	2 x 2m ²	Propylene Glycol	8,50%

F. FEATURES OF SOLAR FLAT PLATE COLLECTOR PANEL

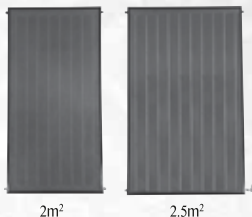

- Black coated aluminum frame, 4mm toughened prismatic and non-reflective anti-hail tempered glass.
- Durable copper waterway tubes.
- Rubber seals ensure durability and reliability in extreme climatic conditions.
- Semi-selective black chrome surface on copper substrate offers maximum absorption efficiency.

PRODUCT CODE	DIMENSIONS (mm)	APERTURE AREA (m ²)	MASS EMPTY(kg)	MASS FULL (kg)	ENERGY TRANSFER FLUID BY SYSTEM	
					Direct	Indirect
SOL-PANEL-2	2000 x 1000 x 80	2	30	32	Water	Propylene Glycol
SOL-PANEL-2.5	2000 x 1250 x 80	2.5	40	46	Water	Propylene Glycol

G. FEATURES OF THE SOLAR VACUUM TUBES

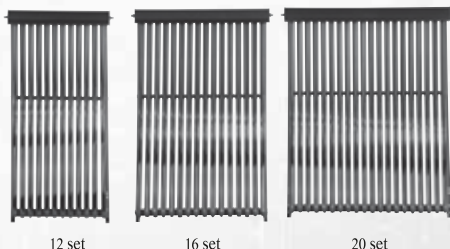

- Consists of two glass tubes (inner and outer) manufactured from Borosilicate glass.
 - The outer tube is transparent allowing light rays to pass through it with minimum reflection.
 - The inner tube is coated with a solar selective coating, which provides excellent solar radiation absorption.
 - The tops of the two tubes are fused together and the air extracted, which forms a vacuum.
- To maintain the vacuum between the two tubes a barium layer is used, which provides a clear visual indication of the vacuum status. The silver coating will turn white if the vacuum is lost.
 - The tubes are installed onto a frame and the tops of the tubes inserted into a manifold. Both are made from anodized aluminum.

H. ROOF LOCATION OF A SOLAR SYSTEM

1. Roof location and pitch

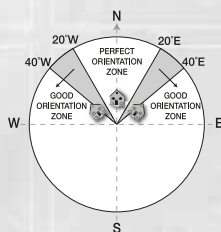

- For optimum performance the solar flat plate collector panel/s or solar vacuum tubes with frame, need to face the equator (facing north for Southern Hemisphere installations). Installation on angles of up to 45° away from the equator do not have a major effect on the annual solar output, consequently roof locations which face less than 45° away from the equator are acceptable. Solar radiance from the sun begins at about 10.00 until 16.00 and at its peak between 12.00 and 14.00.
- If the solar flat plate collector panel/s or solar vacuum tubes are installed with an east facing bias, the best solar capture is achieved in the morning and if installed with a west facing bias, in the afternoon.
- The installation location should not be subject to excessive shading from trees and adjacent buildings and particularly between 9.00 and 15.00. Shadows are longer in winter than in summer so a location that is free of shadows in summer may have some shadows in winter.
- The solar flat plate collector panels or solar vacuum tubes should be installed on a roof pitch greater than 8° and less than 30°. Where the roof pitch is greater than 30°, the installation will require additional support to prevent it from moving downwards when installing and after installing. If the pitch is less than 8°, the installation will require a mounting frame to increase the pitch to above 8°. Installations below 8° do not thermosyphon effectively and the solar flat plate collector panel/s or vacuum tubes will not clean properly when it rains.



- For a flat roof, a flat roof frame with a load spread beam on the rear legs, that protrude at least 300mm past each leg, is available from **Electrolux**.
- Careful inspection must be carried out to ensure that the roof can support the weight of the entire solar installation once it is filled with water.

2. Determining the roof mounting location - Close Coupled and Split Systems

- Once the installation position has been determined outside on the roof for a close coupled system, measure down the roof from the right side front edge of the front foot of the solar water heater a distance of 2030mm and make a mark on the roof tile. This position will be the bottom of the edge of the solar flat plate collector panel/s mounting rail or the bottom edge of the frame for the solar vacuum tubes. This procedure is not relevant for a split system.

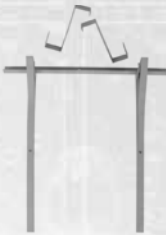

- A Pitch Roof Support with Panel Hooks is available from **Electrolux**. The hook is fed under the roof tiles and hooked around a strip of the roof brandering.
- Once the first hook is secure, place the bottom of solar flat plate collector panel into the bracket and centre it on the bracket. Repeat the process if a second solar flat plate collector panel is to be used, using the second hook. This procedure is not relevant for the frame for the solar vacuum tubes.
- Where two solar flat plate collector panels are to be installed, proceed as follows for both a close coupled and split systems:
 - a. Place the first solar flat plate collector panel in the mounting bracket at the left most far end.
 - b. Loosely fit the two collector panel connectors to the two copper tube spigots on the left side of the second solar flat plate collector panel.
 - c. Place the second solar flat plate collector panel on the second roof mounting bracket and slide the two solar flat plate collector panels towards each other, until the two copper tube spigots can be connected.
 - d. Tighten the compression nuts of the connector fittings taking care not to twist the copper tubes of the solar flat plate collector panels. Use the correct size spanner and ensure that the center nut is held steady whilst the compression nuts are tightened.
 - e. Move the two solar flat plate collector panels so that they centrally located on the two roof mounting brackets installed beforehand.
 - For a close coupled system, fit the pitch roof support above the solar flat plate collector panel/s or frame for the solar vacuum tubes, which will hold the solar water in place on the roof.
 - Remove any labels on the glass of the solar flat plate collector panel/s, as not doing so will affect the performance of the panel/s.

I. INSTALLATION OF A SOLAR WATER HEATER SYSTEM

All systems must be installed in accordance with **SANS 10106 and SANS 10254**, which must include a 400kPa Pressure Control Valve, Vacuum Breakers on both the cold water supply and the hot water draw off, Kwikot Drain Cock and Kwikot Safety Valve.

The solar water heater and solar flat plate collector panel/s or manifold for the solar vacuum tubes must be connected by using 22mm copper piping, 22mm female Conex fittings and/or 22mm copper elbows and tee-pieces and R1 thermal pipe lagging.

1. Thermosyphon Close Coupled System method - Direct & Indirect systems with flat plate collector panel/s

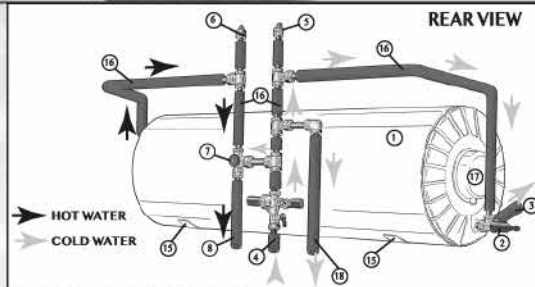
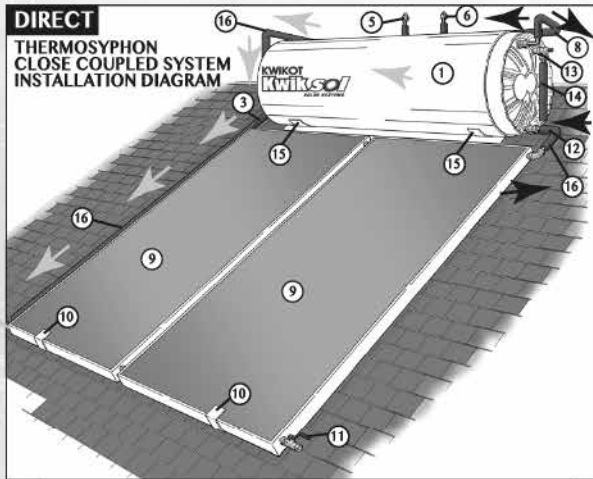

PRODUCT DESCRIPTION	
1 Solar Water Heater Direct, 400kPa	10 Roof Mounting Brackets for Solar Collector Panel
2 Drain Cock Combination Valve (KH5-005)	11 Lever Ball Valve
3 Cold Water Feed to Solar Collector Panels	12 Hot Water Feed to Solar Water Heater
4 Pressure Control Valve, 400kPa	13 Safety Valve, 400kPa
5 Vacuum Breaker Cold Side	14 Safety Overflow Pipe
6 Vacuum Breaker Hot Side	15 Pitch Roof Support for Solar Water Heater
7 Thermostatic Mixing Valve	16 Thermal Pipe Lagging (R1 Rating)
8 Hot Water Feed to Taps (Balanced Pressure)	17 Electrical Cover Plate
9 Solar Collector Panels	18 Cold Water Feed to Taps (Balanced Pressure)

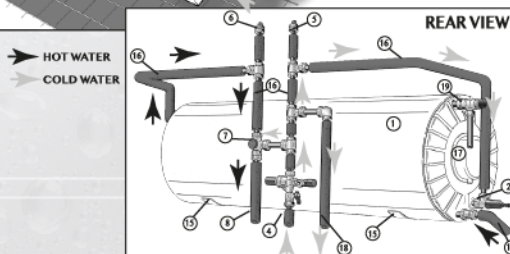
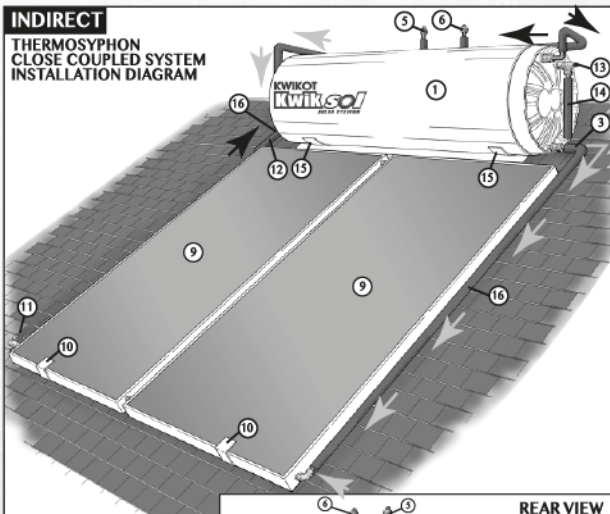

PRODUCT DESCRIPTION	
1 Solar Water Heater Indirect, 400kPa	10 Roof Mounting Brackets for Solar Collector Panel
2 Drain Cock	11 Lever Ball Valve
3 Cold Water Feed to Solar Collector Panels	12 Hot Water Feed to Solar Water Heater
4 Pressure Control Valve, 400kPa	13 Safety Valve, 400kPa
5 Vacuum Breaker Cold Side	14 Safety Overflow Pipe
6 Vacuum Breaker Hot Side	15 Pitch Roof Support for Solar Water Heater
7 Thermostatic Mixing Valve	16 Thermal Pipe Lagging (R1 Rating)
8 Hot Water Feed to Taps (Balanced Pressure)	17 Electrical Cover Plate
9 Solar Collector Panels	18 Cold Water Feed to Taps (Balanced Pressure)
	19 Expansion Valve 100kPa



Once the solar flat plate collector panel/s have been installed on the roof, the solar water heater has to be installed above the solar flat plate collector panel/s or frame and manifold of the solar vacuum tubes, the following procedure must be followed:

- The feet on the solar water heater must be moved to the 30° angle holes on the solar water heater.
- The starting point is the solar water heater front foot. The front foot must be located over a tile batten or purlin for maximum strength.
- The solar water heater centre should be installed evenly over rafters/trusses so as to spread the weight over an even area of the roof.
- Once the position has been determined, mark the position. Install the pitch roof support with solar water heater cradle available from Electrolux at the marked position.
- Place the solar water heater into the cradle.

2. Thermosyphon Split System method - Direct & Indirect systems with solar flat plate collector panel/s

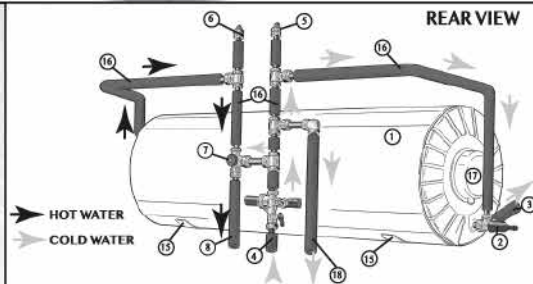
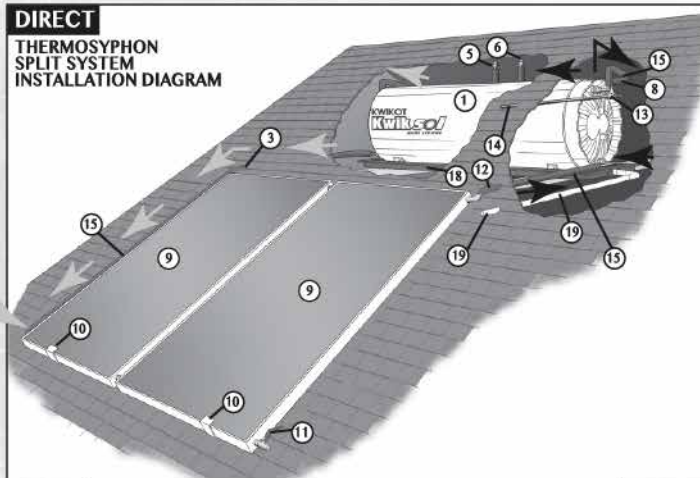

PRODUCT DESCRIPTION

1 Solar Water Heater Direct, 400kPa	10 Roof Mounting Brackets for Solar Collector Panel
2 Drain Cock Combination Valve (KH5-005)	11 Lever Ball Valve
3 Cold Water Feed to Solar Collector Panels	12 Hot Water Feed to Solar Water Heater
4 Pressure Control Valve, 400kPa	13 Safety Valve, 400kPa
5 Vacuum Breaker Cold Side	14 Safety Overflow Pipe
6 Vacuum Breaker Hot Side	15 Pitch Roof Support for Solar Water Heater
7 Thermostatic Mixing Valve	16 Thermal Pipe Lagging (R1 Rating)
8 Hot Water Feed to Taps (Balanced Pressure)	17 Electrical Cover Plate
9 Solar Collector Panels	18 Cold Water Feed to Taps (Balanced Pressure)

INDIRECT
THERMOSYPHON
SPLIT SYSTEM
INSTALLATION DIAGRAM

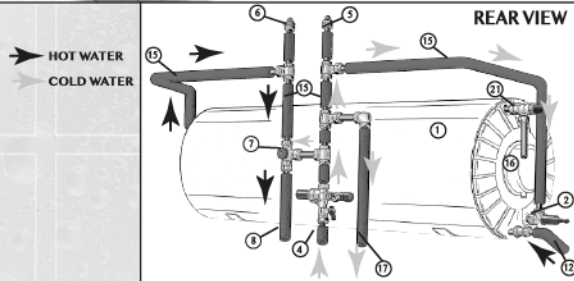
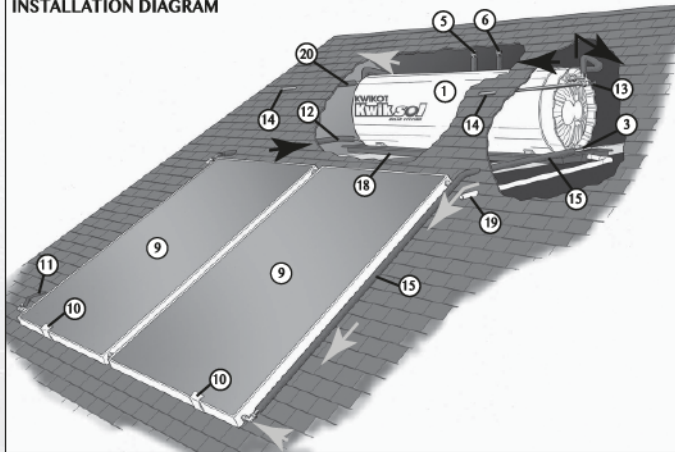

PRODUCT DESCRIPTION	
1	Solar Water Heater Indirect, 400kPa
2	Drain Cock
3	Cold Water Feed to Solar Collector Panels
4	Pressure Control Valve, 400kPa
5	Vacuum Breaker Cold Side
6	Vacuum Breaker Hot Side
7	Thermostatic Mixing Valve
8	Hot Water Feed to Taps (Balanced Pressure)
9	Solar Collector Panels
10	Roof Mounting Brackets for Solar Collector Panel
11	Lever Ball Valve
12	Hot Water Feed to Solar Water Heater
13	Safety Valve, 400kPa
14	Safety Overflow Pipe
15	Thermal Pipe Lagging (R1 Rating)
16	Electrical Cover Plate
17	Cold Water Feed to Taps (Balanced Pressure)
18	Drip Tray
19	50mm Overflow from Drip Tray
20	Expansion Valve 100kPa

Once the solar flat plate collector panel/s have been installed on the roof, the solar water heater has to be installed inside the roof at a higher plane to the solar flat plate collector panel/s outside on the roof, the following process must be followed:

- a. A geyser drip tray which complies to **SANS 11848** must be placed on the tie beams over a load-bearing wall and supported by timber that complies with at least Grade 5 **SANS 1783-2** and of a size at least 120mm x 30mm spaced not than 500mm apart.
- b. The solar water heater is to be placed inside the geyser drip tray.

3. Split Pump Circulation method - Direct & Indirect Systems with solar flat collector panel/s

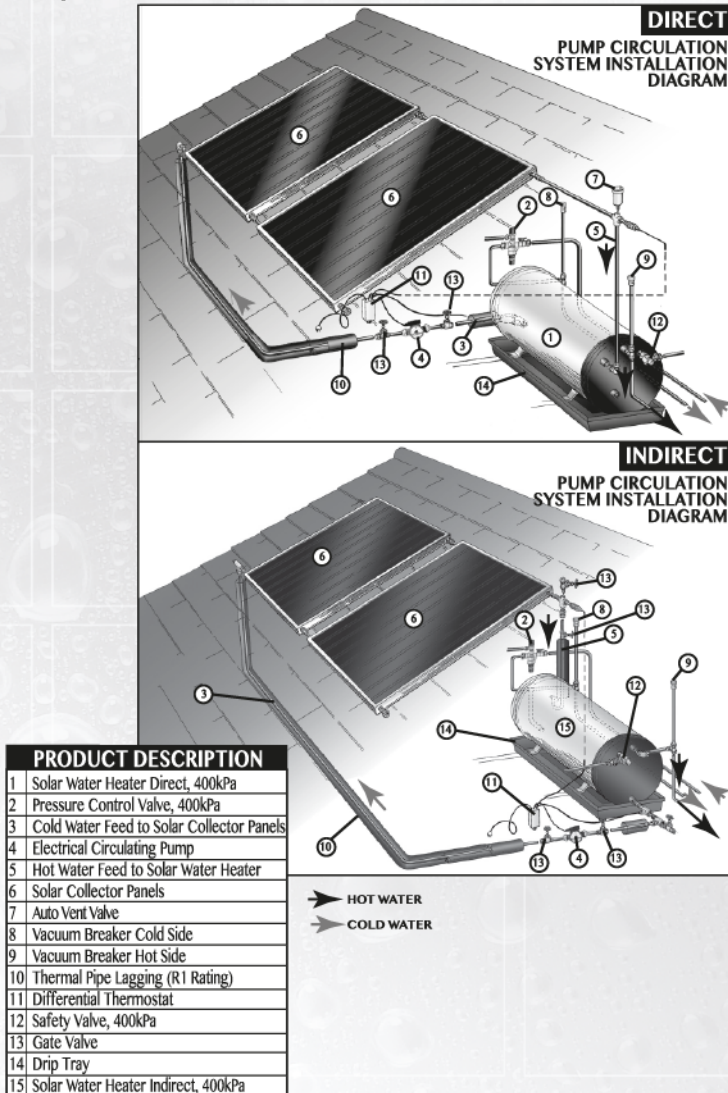

Once the solar flat plate collector panel/s have been installed on the roof, the solar water heater has to be installed inside the roof, the following process must be followed:

- A geyser drip tray which complies to **SANS 11848** must be placed on the tie beams over a load-bearing wall and supported by timber that complies with at least Grade 5 **SANS 1783-2** and of a size at least 120mm x 30mm spaced not than 500mm apart.
- The solar water heater is to be placed inside the geyser drip tray

4. Close Coupled Thermosyphon method - Direct system with solar vacuum tubes

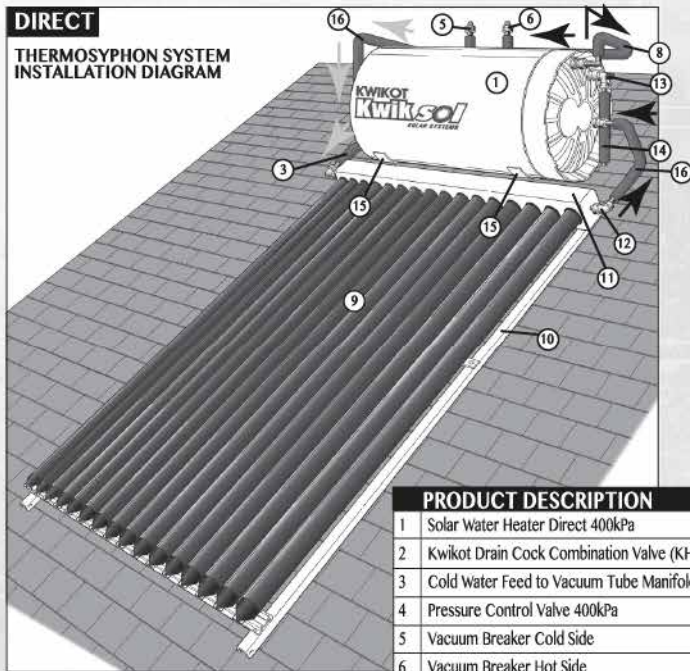

PRODUCT DESCRIPTION

1	Solar Water Heater Direct 400kPa
2	Kwikot Drain Cock Combination Valve (KH5-005)
3	Cold Water Feed to Vacuum Tube Manifold
4	Pressure Control Valve 400kPa
5	Vacuum Breaker Cold Side
6	Vacuum Breaker Hot Side
7	Thermostatic Mixing Valve
8	Hot Water Feed to Taps (Balanced Pressure)
9	Solar Vacuum Tubes
10	Solar Vacuum Tube Frame
11	Solar Vacuum Tube Manifold
12	Hot Water Feed to Solar Water Heater
13	Safety Valve 400kPa
14	Safety Overflow Pipe
15	Pitch Roof Support for Solar Water Heater
16	Thermal Pipe Lagging (R1 Rating)
17	Electric Cover Plate
18	Cold Water Feed to Taps (Balanced Pressure)

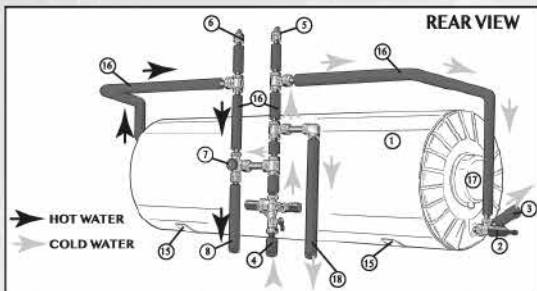

Once the solar vacuum tube frame and manifold have been installed on the roof, the solar water heater has to be installed above the manifold, the following procedure must be followed:

- a. The feet on the solar water heater must be moved to the 30° angle holes on the solar water heater.
- b. The starting point is the solar water heater front foot. The front foot must be located over a tile batten or purlin for maximum strength. The solar water center should be installed evenly over rafters/trusses so as to spread the weight over an even area of roof.
- c. Once the position has been determined, mark the position. Install the pitch roof support with solar water heater cradle available from Electrolux at the marked position.
- d. Place the solar water heater into the cradle.



5. Important Installation Information

- a. In an Indirect system installation, the solar water heater must be fitted with an Expansion Relief Valve 100kPa on the left top side of the front end dome.
- b. All cold and hot water pipe connections to and from the solar water heater, must have at least 1m of thermal lagging installed on the pipe work.
- c. The copper discharge pipes connected to the Expansion Control Valve 100kPa and on the Safety Valve on the solar water heater in a close coupled system installation, must face downwards (vertical) towards the roof. In a split system, these pipes must be lead to the exterior of the building or roof, with a continuous downward fall and the outlets being left open to the atmosphere.

NB!

All Kwikot Kwisol Solar Water Heating systems are supplied as pitched roof mounting and no flat roof frame is included.

Flat roof frames are available an optional extra.

J. FILLING A SOLAR SYSTEM

a. Direct System – Thermosyphon Circulation Method

- Do not switch 'ON' the electrical supply to the solar water heater until the system has been filled with water.
- Open the cold water supply to the solar water heater and the entire system will self-fill. To ensure that all air is out of the system, open the lever ball valve at the bottom on the solar flat plate collector panel/s and allow the water to flow out for about 15 seconds. Close the lever ball valve.
- Where solar vacuum tubes are used, the manifold at the top of the tubes will fill up.
- Check the entire system for water leaks and shut 'OFF' the water supply where leaks need to be repaired.
- Once leaks have been repaired, the water supply can be opened to refill the system. Open a hot tap to allow air to escape until the airbursts have stopped and the water flows freely from the tap. Close the tap.

b. Indirect System – Thermosyphon Circulation Method

- A dilution of Propylene Glycol and water has to be used in this system.
- The dilution ratio's as follows:
- Ambient temperatures in winter 5°C to -8°C, one part Propylene Glycol to three parts water i.e. Propylene Glycol 1lt with 3lts of water.
- Ambient temperatures in winter -9° to -16°C, one part Propylene glycol to two parts water i.e. Propylene Glycol 1lt with 2lts of water.
- Do not switch 'ON' the electrical supply to the solar water heater until the system has been filled with water.
- Cover the solar flat plate collector panel/s to prevent pressure variation due to thermal activity in the solar flat plate collector panel/s.
- Open the cold water supply to the solar water heater and check for any leaks.
- Remove the 100kPa Expansion Relief Valve from the socket on the front end of the solar water heater.
- Connect a 15mm (½") flexible hose to the lever ball valve in the open position, at the bottom of the solar flat plate collector panel.
- With the use of a funnel, pour 1lt bottle of Propylene Glycol into the funnel. Using the same bottle, add two or three bottles of tap water, dependent on the extreme ambient temperatures in the area during winter. If the poured diluted liquid does not flow from the open socket where the Expansion Relief Valve is installed, repeat the process until the liquid flows from the socket.

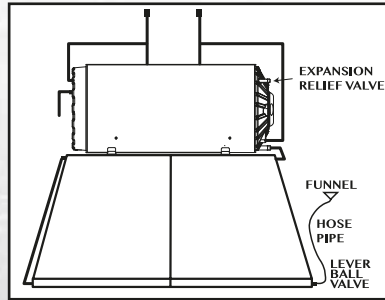

- Once filled, close the lever ball valve on the solar flat plate collector panel and remove the hose and funnel.
- Re-fit the 100kPa Expansion valve.
- Check all connections for leaks.
- Switch 'ON' the electrical supply to the solar water heater and the system is now operational.

K. DRAINING AN INDIRECT SOLAR SYSTEM

The dilution of Propylene Glycol and water must be drained from the system and replaced every three years.

- Connect a 15mm (½") flexible hose to the lever ball valve at the bottom of the solar flat plate collector panel.
- Hold the other end of the hose in a bucket or any other suitable container.
- Open the lever ball valve and the heat transfer fluid will flow in to the bucket until the system is empty.
- It would be advisable to measure how much heat transfer fluid emptied out in the bucket, as this will provide a good indication of how much has to be replaced into the system.
- Never allow the heat transfer fluid to empty out onto a roof or gutter that collects rain water or feeds a water storage tank.

L. GENERAL MAINTENANCE OF THE SOLAR SYSTEM - FOR THE HOMEOWNER

- During the summer period, the solar flat plate collector panel/s and solar vacuum tubes will be kept clean by normal rainfall. In winter and especially in the inland areas where a lot of dust build up occurs, the solar flat plate collector panel/s and solar vacuum tubes can be hosed down. A soft broom can be used with a regular household window cleaning detergent to remove bird droppings. Do not press heavily on the broom. If a detergent is used, hose down afterwards so no detergent residue remains on the glass.
- The thermal lagging on the exterior pipe work should be checked for degradation every year, particularly before the winter season when heat loss is at its greatest.

- Always be observant to any leaks that may arise over time in the system and repair these as soon as possible.
- Replace the heat transfer fluid in the Indirect System every three years.

M. SAFETY PRECAUTIONS & EMERGENCY SHUTDOWN PROCEDURE - FOR THE HOMEOWNER

1. Safety Precautions

- Do not tamper with any part of the system installation.
- Do not touch the hot supply pipe from the solar flat plate collector panel/s or the manifold for the solar vacuum tubes, as this pipe can get extremely hot, particularly during the summer.
- The draining and replacing of the heat transfer fluid in an Indirect System must only be carried out by someone who has thorough knowledge of solar systems.
- Storage of Glycol Propylene must be placed in a place not accessible to children and pets.

2. Emergency Shutdown Procedure

In the event of a problem arising with the solar system, carry out the following procedure:

- Switch 'OFF' the Geyser/Solar water Heater Switch at the electrical distribution board.
- Any evidence of a water leak from any part of the system, except occasional dripping from the overflow pipe on the Safety Valve, shut off the water supply to the solar water heater at either a shut off valve at or before the solar water heater, or at the water supply mains.
- Any evidence of a heat transfer fluid leak in any part of an Indirect System, try and capture or contain the leaking fluid if possible.
- If the solar system installation is still under the installation warranty period offered by the installer, contact the installer.

N. WARRANTIES – FOR THE HOMEOWNER

It is important to note that the warranty on the solar system installation is separate to that of **Electrolux's** warranty on certain specified solar system products and components.

1. Installer Warranty

- This is the warranty period offered by the installer of the solar system and covers the installation of the system and the working of the solar system for the period specified.
- Water leaks, heat transfer liquid leaks, system faults and incorrect installation of the system resulting in the system not operating or operating properly, must be brought to the attention of the installer.

2. Product Warranty

Electrolux SA (Pty) Ltd ("Electrolux") warrants that its KWIKOT Kwiksol solar water heaters, solar flat plate collector panels, solar vacuum tubes and manifold, drain cock and safety valve, pressure control valve, thermostatic mixing valve,

vacuum breakers and lever ball valves, are free from manufacturing defects. This is the only warranty given by **Electrolux** in respect of these products. **Electrolux** gives no other warranties or representations, whether expressed or implied. No amendments or additions to the warranty shall be binding on **Electrolux**.

Electrolux makes no warranty or representations in respect of the installation of the solar system. Claims in respect of the installation of the solar system must be referred to the applicable installer, who shall be solely liable under any installation warranty given.

The warranty covers the specified products only and does not cover any part of the installation, which may become damaged or faulty as a consequence of the failure of the specified defective **Electrolux** product.

The period during which the warranty is calculated is from the date of installation of the original product, provided that documented proof of the date of installation is furnished. If the installation date is not furnished or can not be proved, the date of manufacture, as determined by **Electrolux** from information on the serial plate where applicable, shall be deemed to be the commencement date of the warranty period.

Where **Electrolux** supplies an auxiliary component from another manufacturer, that manufacturer's warranty period and conditions will apply.

If **Electrolux** carries out repairs or replacements, the warranty period will not start afresh or be extended, irrespective of how many repairs or replacements are carried out. The warranty period will still be calculated from the date of the original installation or manufacture date of the original product, as the case may be. Components removed during the warranty repairs, will remain the property of **Electrolux SA (Pty) Ltd**.

Warranties are applicable only in South Africa, Namibia, Botswana, Swaziland and Lesotho and subject to the solar system being used for water, which is of a quality equivalent to the water supplied by authorities in Metropolitan areas in South Africa.

A warranty will only be honoured if:

- The applicable product warranty period is still in force.
- The solar system is installed, used and maintained in accordance with **Electrolux's** specifications and instructions and relevant **SANS 10254** and **SANS 10106** standards.
- All products included in the installation comply with SANS approvals, including the pressure control valve.
- The solar system has been used for water, which meets **Electrolux's** quality specifications.

The warranty does not cover:

- Element burn out through commissioning without water in the solar water heater.
- Burnouts due to loose electrical connections.
- Fair wear and tear.
- Misuse, abuse or negligent use of the solar system.
- Any attempt to self repair the solar system, tampering or defacing the serial plate.

Electrolux shall not be liable for any claims, losses, liabilities, damages, costs or expenses whatsoever and howsoever arising out of or in connection with the use, functioning or malfunction of the solar system or any part thereof including defects. Without limiting the generality of the afore-going, **Electrolux** shall not in any circumstances be liable for any consequential or direct damages, loss of profits or punitive damages.

Repairs and/or replacements may only be carried out by **Electrolux** and its authorised agents. This warranty will be completely invalidated if any repairs are effected or work undertaken at anytime by any other party without **Electrolux's** authorisation. Specified product warranties are as follows:

1. Kwiksol Solar Water Heaters

- The solar water heater has a comprehensive one-year warranty period on the electrical components and two-year warranty period on the drain cock and safety valve. The solar water heater has been designed and manufactured to work at optimum performance by using genuine **Electrolux** (KWIKOT branded) parts. Should these parts be replaced with non-genuine **Electrolux** (KWIKOT branded) parts whilst the solar water heater is still under warranty, the warranty will not be honoured.
- The inner cylinder of the solar water heater, flange assembly and gasket, have a five-year warranty period. The solar water heater is fitted with a sacrificial magnesium anode, which protects the glass lined inner cylinder. Replacement of the anode should be carried out at intervals depending on the water quality in the specific area, which can be obtained from the relevant water authorities. The following water specification and servicing requirements should be adhered to:

TOTAL DISSOLVED SOLIDS (PARTS PER MILLION)	RECOMMENDED ANODE REPLACEMENT
100-600	3 Years
601-1000	2 Years
Over 1001	1 Year

- Should the the inner cylinder of an Indirect solar water heater implode (collapse), as a result of the Indirect circuit being over pressurised, is not covered by the warranty.
- Any damage caused due to an incorrect dilution of propylene glycol or only water being used in the solar water heater Indirect System circuit, is not covered by the warranty.

2. Solar Flat Plate Collector Panels

- The panels have a five-year warranty period. The warranty only applies to defects, which may have arisen solely due to faulty materials and workmanship during the manufacturing process.
- Any freeze damage caused as a result of the panels being installed as a Direct System in frost and freezing areas which record ambient temperatures below 5°C, is not covered by the warranty.
- Any damage caused to the solar collector panels due to an incorrect dilution of propylene glycol or water being used in an Indirect System, will not be covered by the warranty.
- The glass collector if cracked or broken from whatever cause, is not covered by the warranty

3. Solar Vacuum Tubes and Manifold

- The tubes and manifold have a five-year warranty period. The warranty only applies to defects, which may have arisen solely due to faulty materials and workmanship during the manufacturing process.
- The tubes if cracked or broken from whatever cause, is not covered by the warranty.

O. PERTINENT INFORMATION - FOR THE HOMEOWNER (TO BE COMPLETED BY THE INSTALLER)

a. Installer's Details

Full Name: _____

Company Name: _____

Physical Address: _____

Business Tel: _____ Cell: _____

Email: _____

Details of Kwiksol Solar System Installed

(tick appropriate blocks on table below)

b. Solar Water Heater Serial Number, Code and Installation Date

Serial Number: _____ Code: _____

Date of Installation: _____

c. Installation Warranty Period Offered by the Installer

Number of Months from Installation: _____

Signature of Installer: _____ Date: _____

SYSTEM	CLOSE COUPLED OR SPLIT	CIRCULATION METHOD	TICK HERE
	Close Coupled	Thermosyphon	
Direct (frost-free)	Split	Thermosyphon	
	Split	Pumped	
Direct (frost resistant)	Close Coupled	Thermosyphon	
	Close Coupled	Thermosyphon	
Indirect (frost resistant)	Split	Thermosyphon	
	Split	Pumped	
CAPACITY			
100lt	150lt	200lt	300lt
SIZE AND NUMBER OF SOLAR FLAT PLATE COLLECTOR PANELS			
1 x 2m ²	1 x 2m ²	1 x 2.5m ²	2 x 2m ²
NUMBER OF SOLAR VACUUM TUBES			
12 (2 x 6)	16 (1 x 6 + 1 x 10)	20 (2 x 10)	32 (2 x 10 + 2 x 6)

Electrolux SA (Pty) Ltd Inland Division

PO Box 1016, Benoni, 1500
Tel: (011) 897 4600

Electrolux SA (Pty) Ltd Eastern Cape Division

PO Box 29142, Sunridge Park, Port Elizabeth, 6008
Tel: (041) 399 4000

Electrolux SA (Pty) Ltd Western Cape Division

PO Box 32072, Ottery, Cape Town, 7808
Tel: (021) 690 2700

Electrolux SA (Pty) Ltd Kwazulu-Natal Division

PO Box 47366, Greyville, Durban, 4023
Tel: (031) 574 8700

SUPPORT: Renewable.EnergyInfo@electrolux.com
Technical.Info@electrolux.com
Kwikot.MarketingInfo@electrolux.com



www.kwikot.com

**P. PERTINENT INFORMATION - FOR Electrolux SA (Pty) Ltd
TO VALIDATE THE WARRANTY**

NB. Complete, Scan and Email to: ZA_insure@electrolux.com

a. Homeowner's Details (to be completed by the homeowner)

Full Name: _____

Company Name: _____

Physical Address: _____

Business Tel: _____ Business Email: _____

a. Installer's Details (to be completed by the installer)

Cell: _____ Email: _____

Full Name: _____ Company Name: _____

Physical Address: _____

ID Number: _____

Business Tel: _____ Business Cell: _____

Email: _____

c. Details of Kwiksol Solar System Installed (to be completed by the installer)

Solar Water Heater Serial Number, Code and Installation Date (to be completed by the installer)

Serial Number: _____ Code: _____ Date of Installation: _____

SYSTEM	CLOSE COUPLED OR SPLIT	CIRCULATION METHOD	TICK HERE
	Close Coupled	Thermosyphon	
Direct (frost-free)	Split	Thermosyphon	
	Split	Pumped	
Direct (frost resistant)	Close Coupled	Thermosyphon	
	Close Coupled	Thermosyphon	
Indirect (frost resistant)	Split	Thermosyphon	
	Split	Pumped	
CAPACITY			
100lt	150lt	200lt	300lt
SIZE AND NUMBER OF SOLAR FLAT PLATE COLLECTOR PANELS			
1 x 2m ²	1 x 2m ²	1 x 2.5m ²	2 x 2m ²
NUMBER OF SOLAR VACUUM TUBES			
12 (2 x 6)	16 (1 x 6 + 1 x 10)	20 (2 x 10)	32 (2 x 10 + 2 x 6)



POSTAGE
STAMP

Electrolux SA (Pty) Ltd

PO Box 389

Benoni

1500



