

Kwikpure Top Loading Water Dispenser

Installation and Warranty Manual

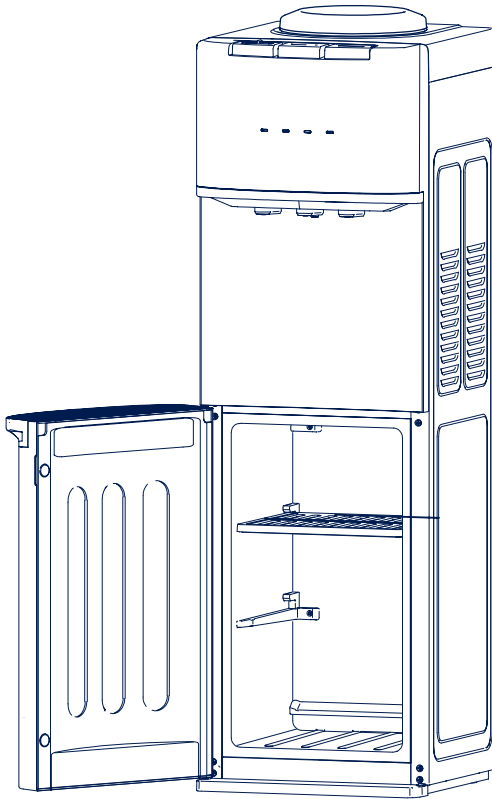

Model:
KDC-TB3B1B-SA
KDC-TB3B1W-SA

Kwikpure Water Dispenser



**Energy
Saving**



**Large
Cold-Water
Tank**

www.kwikot.com



powered by **Haier**

Contents

Safety Instructions	03
Packing List	05
Product Introduction	05
Technical Data	06
Product Parts	07
Product Component	08
Working Principle Figure	08
Electrical Schematic Diagram	09
Installation and Maintenance	10
Unpacking the Water Dispenser	11
Installation Procedure	11
Product Power-on Preparation and Steps	11
Prepare to Use the Water Dispenser	12
Water Dispenser Operation	12
Display Function Description	12
Using the Water Dispenser	13
Cleaning & Maintenance	13
Troubleshooting	14
Recycling	16
Warranty Service	16

Please read this manual carefully before use.

- The company reserves the right to interpret the specification.
- The appearance of the product is subject to the actual product.
- Please keep it together with the invoice after reading.

Safety Precautions



When using electrical appliances, basic safety precautions should be followed to reduce the risk of fire, electric shock, and injury to persons or property. Read all instructions before using any appliance.

1. The unit must be properly grounded before use. Improper use may cause life and property damage.
2. Do not let hot water touch bare skin. Keep combustible materials such as furniture, bedding, pillows, clothes, papers away from the back of the unit.
3. Do not operate this, or any other appliance, with a damaged power cord. No other appliance should be plugged into the same outlet. Be sure that the plug is fully inserted into the outlet.
4. Do not run the power cord over carpeting or other heat-insulating materials. Do not overload the cord. Keep cord away from high traffic areas, and do not submerge in water.
5. We do not recommend the use of an extension cord as it may overheat and pose a fire risk.
6. Exercise caution and supervise children when the appliance is in use or near children.
7. Do not use your water dispenser outdoors. Place the water dispenser away from direct sunlight and make sure that there is at least 15cm of space between the back of your unit and wall. Keep a minimum of 5cm on each side of your unit free.
8. Do not use this product to dispense anything other than water.
9. To avoid a hazard due to instability of the appliance, it must be placed on even and flat surface.
10. If the supply cord is damaged, the manufacturer or its service agent or a similarly qualified person must replace it in order to avoid a hazard.
11. Position this water dispenser in a way that the plug remains easily accessible.
12. Disconnect the plug from the outlet when not in use.
13. Remove power plug or disconnect from the main power source before servicing the appliance.
14. Attention: Wait until water flows from the faucet before switching on the power supply to prevent damage to the unit.
15. This product is not recommended to be used in areas above 3,000 m altitude.
16. The appliance is not to be used by persons (including children) with reduced physical, sensory or mental capabilities, or lack of experience and knowledge, unless they have been given supervision or instruction.



Safety Precautions

 <p>Forbidden</p>	<p>Actions or operations that are strictly prohibited.</p>	 <p>Warning</p>	<p>Violations may result in serious personal injury or death.</p>
 <p>Caution</p>	<p>Actions or operations that must be followed.</p>		





Prohibited

 <p>Avoid Direct Sunlight</p>	<p>Avoid installation in places exposed to direct sunlight or outdoors.</p>	 <p>Frost Protection</p>	<p>Do not store or expose the product to environments below 0°C.</p>
 <p>Heat Exposure</p>	<p>Do not store flammable, explosive, or heat-sensitive items that may deform or deteriorate near the unit.</p>		

Warning

 <p>Fault Handling</p>	<p>In case of machine malfunction, quickly shut off the water supply.</p>	 <p>Keep Away from Children</p>	<p>Do not allow children to operate.</p>
 <p>Emergency Call</p>	<p>For assistance, please contact the local sales service center.</p>		

Caution

 <p>Maintenance</p>	<p>Do not disassemble any parts of the machine by yourself to prevent water leakage and damage.</p>	 <p>Temperature</p>	<p>Use the machine in a dry environment between 4°C and 40°C.</p>
 <p>Out of use</p>	<p>If you do not use the Water dispenser for more than 24 hours, please turn off its power and water supply</p>	 <p>Proper Repair Service</p>	<p>Only professionally trained and certified personnel designated by our company are authorized to repair this machine.</p>

Packing List

Name	Quantity
Main Unit	1
Instruction Manual and Warranty Card	1
Accessory Bag	1

Note: The accessories included shall be subject to the actual material.

Product Introduction

Product Introduction

Category	Parameter	
Product Model	KDC-TB3B1B-SA	KDC-TB3B1W-SA
Rated Voltage	230 V ~	
Rated Frequency	50 Hz	
Heating Power	460 W	
Cooling Current	≤0.8A	
Hot Water	≥85°C 4.5 L/h	
Cold Water	≤10°C 2.5 L/h	
Climate Type	T	
Refrigerant	R134a,32g	
Relative Humidity	≤90%	
Protection of Anti-Electric-Shock	I	
Country of origin	Made in China	

Product Introduction

Product Parts

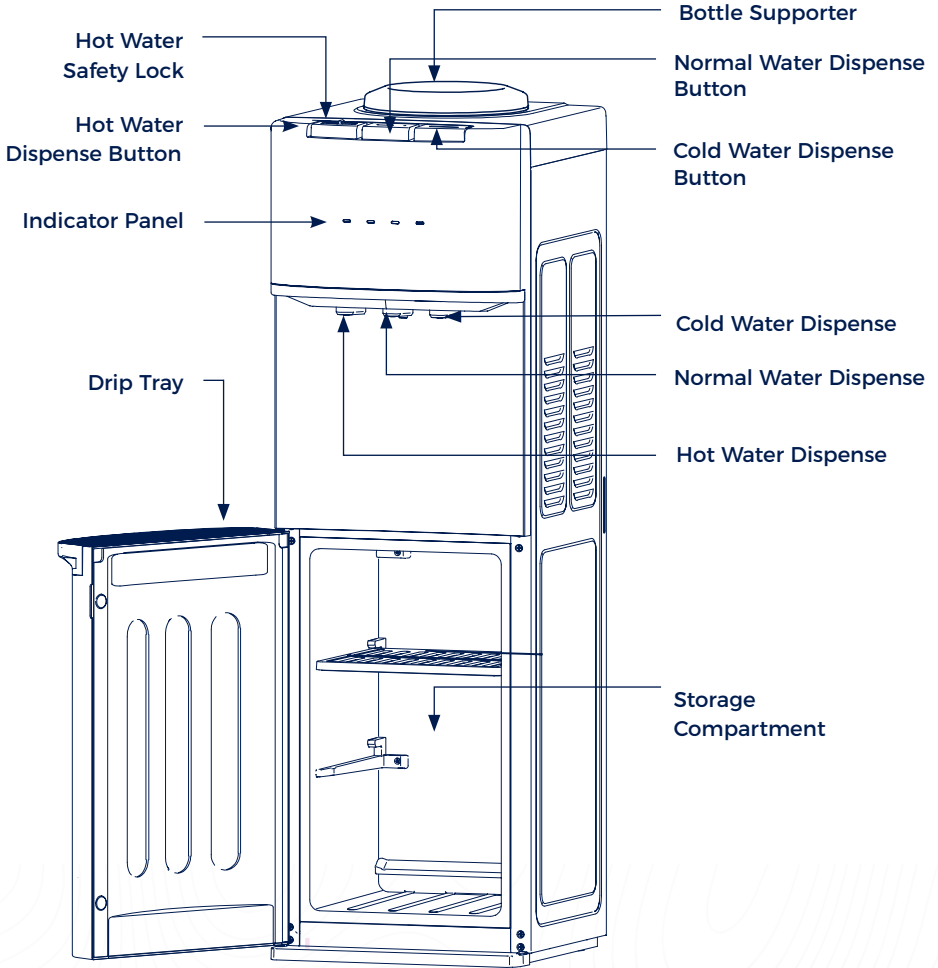

Product Introduction

Product Component

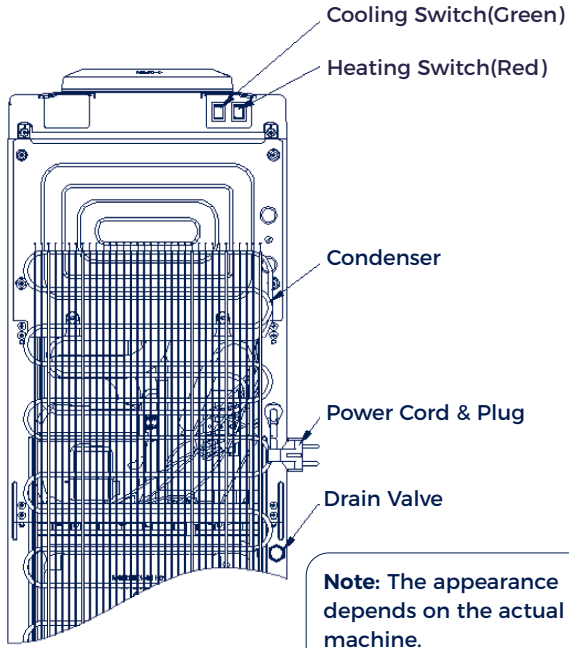

Working Principle Figure

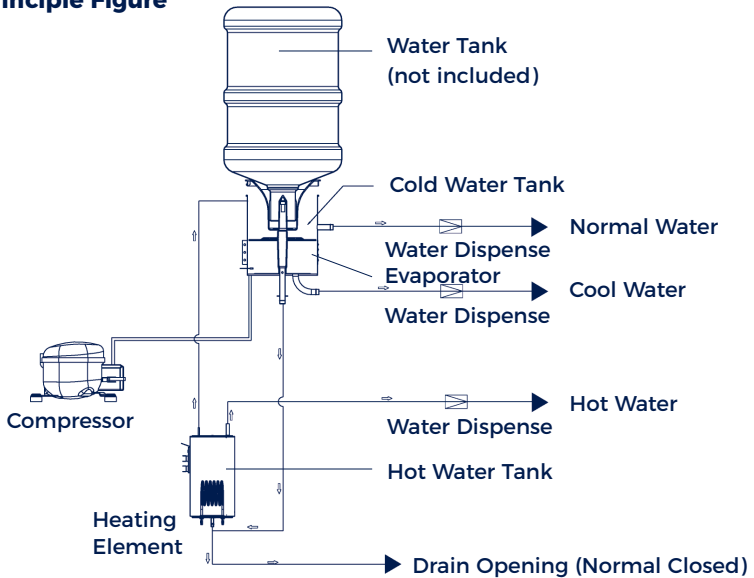

Product Introduction

Electrical Schematic Diagram

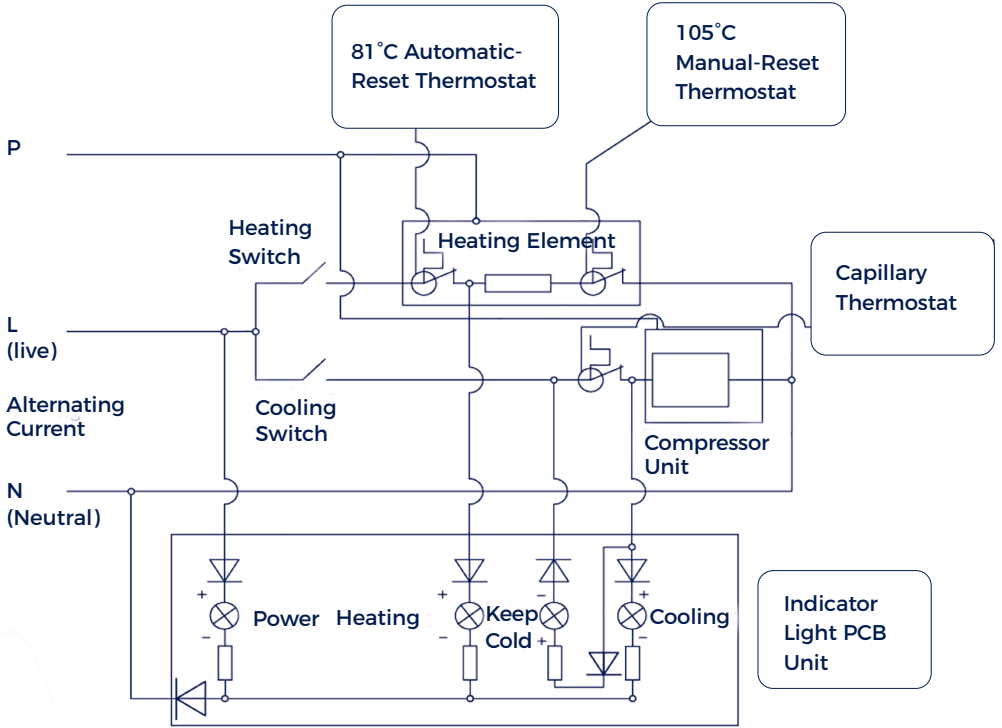

Installation and Maintenance

Unpacking the Water Dispenser

After purchasing a Kwikot Water Purifier, users shall have it installed and commissioned by professional personnel. Before installation, please confirm that all accessories in the packaging are complete.

1. Cut and remove the straps from the box. **Do not** turn the box upside down or lay it on its side. The bottom of the box is separated from the top section. Lift straight up on the top box section to remove the top box section. Remove the Styrofoam packaging and plastic bag. Lift the water dispenser off the bottom of the box. Wipe it clean if necessary.
2. Place the machine on a hard, flat surface. Make certain the unit is levelled. The unit should not be placed near to direct sunlight or other source of heat.
3. It is best to place the water dispenser in an area with good air circulation. Make sure there is at least 15cm of space between the back of your water dispenser and the wall. Keep a minimum distance of 5cm on each side of your water dispenser.
4. After the water dispenser is installed, do not connect the power supply immediately. Wait at least 2 hours before turning it on for use.

Warning: The drain cap on the back of the unit may become loose during shipping. Fasten the drain cap tightly before you start to operate the unit. If the drain cap is loose, the unit may leak and cause floor damage.

Installation Procedure



Note: The installation of the fixed bracket is to prevent children or other accidental operations to make the machine topple, causing damage to the machine and harm to personal safety, it can also prevent accidents caused by natural disasters. Please follow the instructions below to install the machine before using it.

1. Take out the accessory package (including an expansion tube and a self-tapping screw) from the machine.

Installation and Maintenance

Installation Procedure

2. Drill holes in the floor corresponding to the installation position of the machine. If the floor is too hard, you can use an electric drill to drill holes.
3. Insert the expansion tube into the drilling hole, place the machine in the appropriate position, and connect it to the ground with screws through the fixed hole of the machine (in the left back corner of the machine) to ensure a firm connection. After installation, the machine is ready for use.

Installation Procedure

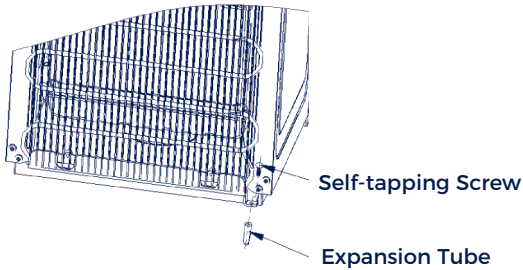

Product Power-on Preparation and Steps

1. Make sure the water dispenser is not plugged into an electrical outlet.
2. Place the water bottle upside down onto the unit's bottle holder. Don't plug the power cord or turn on the heating switch unless water could run out from the hot water faucet.
3. Allow 1-2 minutes for water to dispense from the hot water outlet. Once water flows, activate the heating or cooling function via the switch on the rear of the unit.
4. The cooling system activates immediately but requires approximately 30 minutes to get cold water at a lower temperature.

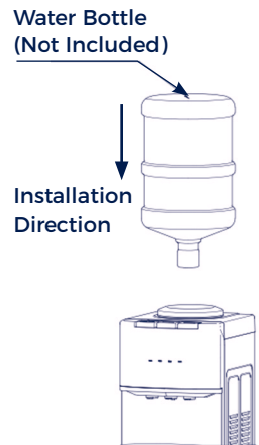

Installation and Maintenance

Prepare to Use the Water Dispenser





Before the new machine is used, it is recommended to flush the water dispenser water pipe with 1 to 20 litres of drinking water (5 gallons/barrel).

Water Dispenser Operation

Turn the power switch on the back of the unit to ON. The water dispenser will start running.

The system first fills the hot and cold water tanks completely, then automatically activates the compressor and heating elements. The first time the water dispenser is used, you will have to wait at least half an hour for hot and cold water tank filling and heating or cooling.

Display Function Description

Display Icons	
Icon	Icon Instructions
	The indicator light shows the heating status: on for heating, off when complete.
	The indicator light shows the cold preservation status: on for cold water temperature lower than 10°C, off when the cooling function is activated.
	The indicator light shows the cooling status: on for cooling, off when complete.
	The indicator light shows the machine power status: on for powered on, off when power disconnected from the power supply.

Installation and Maintenance

Using the Water Dispenser

To dispense hot water, slide the hot water handle to the left side and then push the button all the way in.

To dispense cold water, push the cold water button all the way in.

To dispense normal water, push the normal water button all the way in.

Cleaning & Maintenance

1. To avoid accidents, turn off and unplug the water dispenser from the outlet before cleaning.
2. A soft damp cloth may be used to clean the surface of the water dispenser. When necessary a mild detergent may be used. **DO NOT** use corrosive chemical solvents to clean the unit, as this may damage the surface of the water dispenser.
3. Do not pour water on the exterior of the unit to avoid getting the internal electrical system wet. **DO NOT** immerse the unit in water when cleaning.
4. The water dispenser drip tray may be washed in a dishwasher.
5. Keep the water dispenser (15cm) away from the wall so it can work properly. Make certain all ventilation openings are clear of obstruction.
6. Do not damage the heating or cooling system, paying particular attention to the black condenser or heating radiator on the back of the water dispenser.
7. If you will not use the water dispenser for a long period of time, please unplug the power cord and drain the water cooler. Drain the water from all faucets, then remove the drain cap on the back of the unit and allow it to drain. Make certain the drain cap is fastened tightly when finished.

Troubleshooting

Please check the troubleshooting chart below. It includes several common problems, which you can correct at home, making a customer service call unnecessary.

Troubleshooting		
Failure Phenomenon	Possible Causes	Remedy
Unit does not dispense hot and cold water	Unit is unplugged	Plug the power cord into an outlet
	Main power supply is off	Re-establish main power supply
	Damaged water dispenser	Replace the dispenser or send for service
Unit does not dispense cold water	Over consumption of cold water in a short time	Wait a moment for the water to cool
	System malfunction	Wait a moment for the water to cool
	The ventilation around the unit is insufficient	Space the unit from the wall by more than 15 cm
	The temperature of water in the water bottle is too high. (When the bottle is exposed to direct sunlight for a long time)	Place the water bottle in a cool location out of direct sunlight
Unit does not dispense hot water	Over consumption of hot water in a short time	Wait a moment for the water to heat
	System malfunction	Contact service hotline for repairing
Unit is noisy during operation	The appliance is not level	Place the unit on a level, flat surface

Troubleshooting

Please check the troubleshooting chart below. It includes several common problems, which you can correct at home, making a customer service call unnecessary.

Troubleshooting		
Failure Phenomenon	Possible Causes	Remedy
Water leaks from the taps	The tap has been damaged	Call the service hotline to repair the taps
Water is dripping out of the water dispenser and on to the floor	The hose connector is not connected properly or the inside hot or cold water tanks is leaking	Make sure the hose connector is properly connected. Contact service hotline if a water tank is leaking
	The drain cap on the back is not fastened properly	Tighten the drain cap. If the sealing silicon material inside the drain cap is torn or damaged, then replace with a new one
	The water bottle is broken	Change the water bottle
The water being dispensed has a strange taste	This is not uncommon with new water dispenser. Do not worry, this is not dangerous to your health	Flush the water dispenser water pipe with 20 litres of drinking water again. The strange taste usually goes away after the first bottle has been used up

Recycling



Help protect the environment and human health. Dispose of packaging in the appropriate container for recycling. Help recycle waste electrical and electronic equipment. Do not discard equipment marked with this symbol along with household waste. Return the product to your local recycling facility or contact your local government office.

Warranty

Customer to contact our service center for any warranty related issues.
Production date: The 5th, 6th, and 7th characters from the end of the product serial number represent the day, month, and year of production, respectively.

- Day representation: Numbers 1-9 represent days 1-9, and letters A-X represent days 10-31.
- Month representation: Numbers 1-9 represent January to September, and letters A-C represent October to December.
- Year representation: Numbers 1-9 represent years 2001-2009, and letters A-Z represent years 2010-2033.

Note: The sequence follows accordingly, excluding the letters I and O.

To validate the warranty

Kwikot (Haier) SA Pty Ltd warrants that its Water Dispensers are free from manufacturing defects. This is the only warranty given by Kwikot in respect of its Water Dispensers.

Kwikot gives no other warranty or representations, unless where explicitly implied in writing by authorized Kwikot personnel. No amendments or additions to the warranty shall be binding on Kwikot. Kwikot makes no warranty or representation in respect of the installation of instant Dispenser. Claims in respect of the Water Dispenser installation must be referred to the applicable installer, who shall be solely liable under any installation warranties given.

The installer is liable to advise the end user whether the respective Dispenser purchased is fit for purpose in the environment it is intended to be used and the correct size Dispenser is to be recommended for the end users required usage.

To validate the warranty

The two years warranty covers the Dispenser only and does not cover any other part or parts used in the installation, which may become damaged as a consequence of the failure or defect of the Dispenser.

Kwikot will repair, or at its own discretion, replace the faulty part with a new or re-manufactured one. The two years warranty period will be calculated from the date of purchase or the date of installation of the original Dispenser.

If Kwikot carries out repairs or replacements, the warranty will not start afresh or be extended, irrespective of how many repairs or replacements are carried out. Components removed during warranty repairs, will remain the property of Kwikot.

Warranties are applicable only in South Africa, Namibia, Botswana, Swaziland and Lesotho and are subject to Water Purifiers being used for water, which is of the quality equivalent to SANS 241 drinking water quality.

Damage due to freezing is not covered under warranty. Please see manual for more information on protecting the unit.

To validate the warranty (Please register online)

A warranty will only be honored if:

- a. The applicable warranty is still in force/valid.
- b. The Water Dispenser is installed, used and maintained in accordance Kwikot specifications and instructions.
- c. Where applicable, all other products used in the installation must comply with SANS. Non-compliant SANS products will result in forfeiting the warranty.

Kwikot has taken a significant step towards enhancing their customer service by introducing new Water Care product registrations. Through this new process, customers and installers can register their water heaters and water care products by scanning the product registration QR code via a smart phone or manually entering information on **www.kwikot.com**

This registration process enables service agents to access product information promptly, allowing for more efficient handling of warranty claims and a convenient experience for customers. This initiative reflects our unwavering commitment to delivering exceptional service to our valued customers.







Support



Warranty and Service Support

za_insure@kwikot.com

0861 594 568



Admin, Marketing and Product Queries

kwikot.marketinginfo@kwikot.com



Sales and Payment Queries

za_salesorders@kwikot.com

011 897 4600



Technical Queries

technical.info@kwikot.com

Branches

Gauteng
3 Aberdeen Road,
Industrial Sites,
Benoni
(011) 897 4600

Western Cape
15 Purdey Road,
Sheffield Business Park,
Philippi, Cape Town
(021) 690 2700

KwaZulu-Natal
814 Peter Close,
Springfield Park,
Durban
(031) 574 8700

Eastern Cape
39-41 Leadwood Crescent,
Fairview,
Port Elizabeth
(041) 399 4000

Edition: 2025 Edition A
Special Number: 019050xxx
Manufacturer Code: V0000

One Dimensional
Code



Please Recycle