

Full Specification sheet

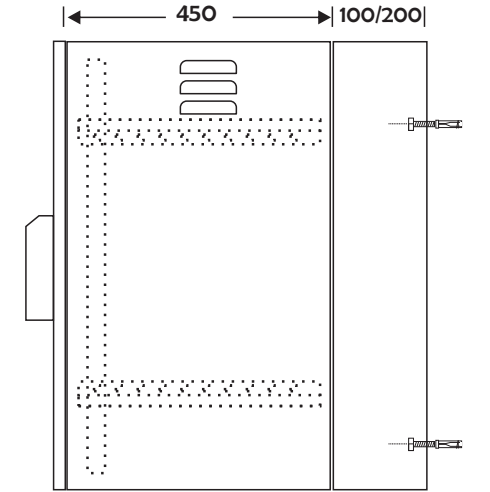

Code 550mm Deep (100 collar)	kg nett
IP55WM4U-550-ODG	19
IP55WM6U-550-ODG	22
IP55WM9U-550-ODG	27
IP55WM12U-550-ODG	32
IP55WM15U-550-ODG	38
IP55WM20U-550-ODG	48

Code 650mm Deep (200 collar)	kg nett
IP55WM4U-650-ODG	22
IP55WM6U-650-ODG	26
IP55WM9U-650-ODG	32
IP55WM12U-650-ODG	39
IP55WM15U-650-ODG	43
IP55WM20U-650-ODG	57

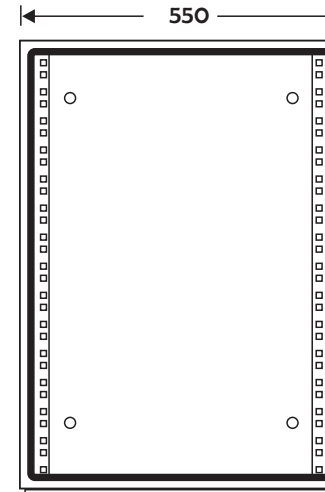
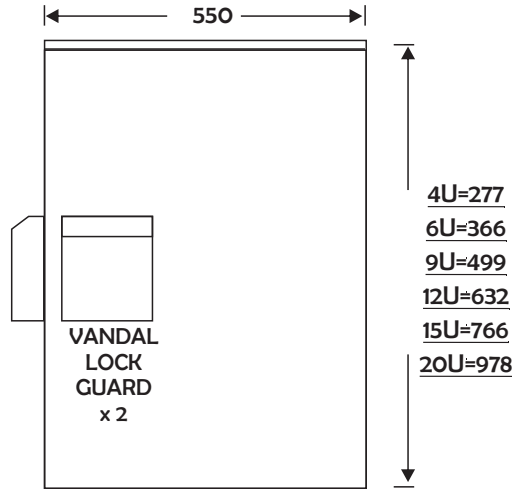

4 x M6 Wall Bolts Supplied

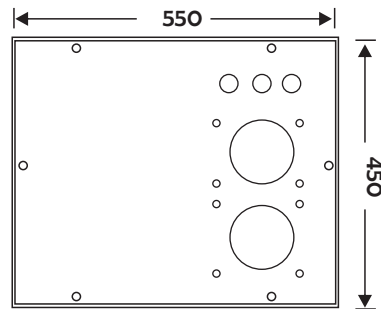
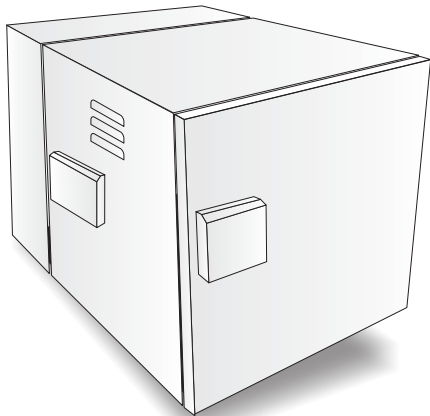

GLAND PLATE 2 FANS (VENTED)

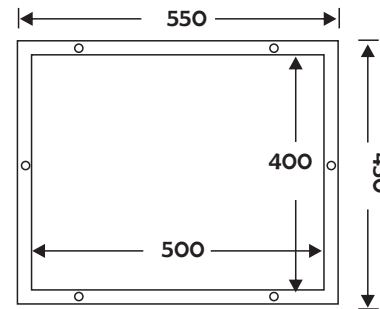

BOTTOM ENTRY

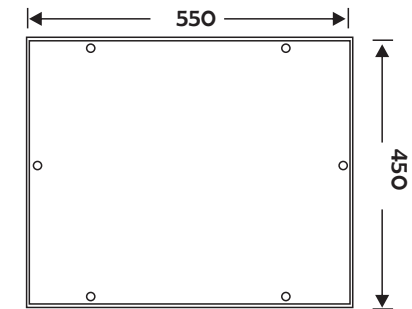

GLAND PLATE PLAIN

Cabinets manufactured to International 19" standards: EIA



Certificate no: Infra 3817	Description: ARIES IP55 19" Std. Swing Frame Box	Third angle projection	Drawn: RL	Drawing No: E241	Sheet: 1-1	Rev:	Date:	Description of changes:	Author: RL
						o	24-7-25		
Item: Aries Cabinets	Colour 1: Zinc Primer Colour 2: G29 GREY. Outdoor, UV Resistant	Tolerances 0. = +/- 1.0mm 0.0 = +/- .5mm 0.00 = +/- .2mm	Checked: ML	Cabinets manufactured to International 19" standards: EIA					
bsi ISO 9001 Quality Management Systems Cert no. FS678923	Material: Body: 1.2 mm C.R.M.5 Prime Stock Mounting Rails: 1.6mm Alu-Zinc. Screws E.galv	Pre-Paint: Seven Stage : Iron & Zinc Phosphate & Passivate Process	Finish: Powder Coat, min 140 microns	Baking: 60 mins. @ 200 C					