

New Plus 42 - 45



★ **La pompa centrifuga** di fabbricazione C.I.M.A. (senza membrane e valvole) costruita in materiale anticorrosivo è esente da manutenzione. La cinghia di trasmissione 3V è dotata di tenditore automatico.

★ C.I.M.A.'s centrifugal pump (no diaphragms or valves), is made of anticorrosive material and does not require any maintenance. The pump is driven by a 3-V belt equipped with an automatic tensioner.

- ★ Telaio in acciaio, verniciatura elettrostatica con polvere poliestere e predisposto per applicare coppia ruote.
- ★ Cerchio di protezione delle testate.
- ★ Ventola centrifuga chiusa ad alta pressione, in acciaio, con disinnesto; carter in polietilene rotazionale.
- ★ Controllo dal posto operatore dell'erogazione con due elettrovalvole.



- ★ Regolatore di pressione manuale (a comando elettrico dal posto operatore a richiesta).
- ★ Manometro (ø100) ben visibile dal posto operatore.
- ★ Filtro di grande portata: 240 l/min.

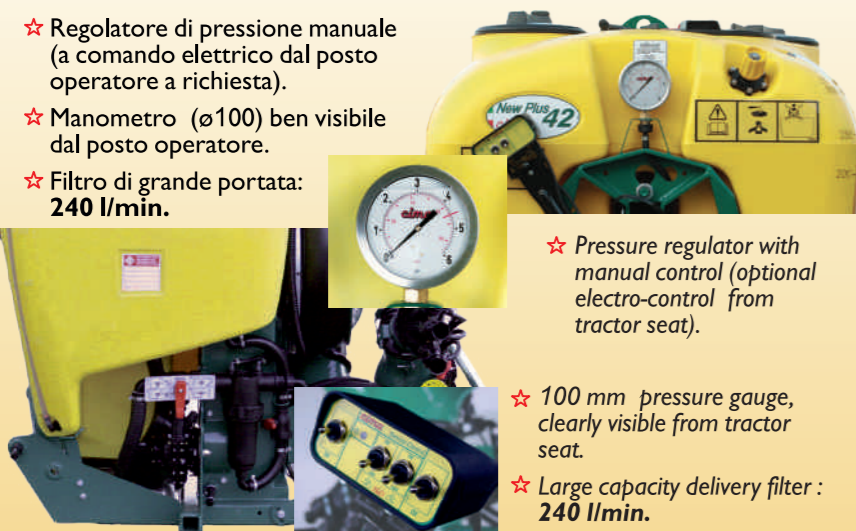

- ★ Pressure regulator with manual control (optional electro-control from tractor seat).
- ★ 100 mm pressure gauge, clearly visible from tractor seat.
- ★ Large capacity delivery filter: 240 l/min.



INFORMAZIONI TECNICHE TECHNICAL INFORMATION

		New Plus 42	New Plus 45
	TRATTRICE TRACTOR	potenza richiesta 18 kW - 25 CV required power 18 kW - 25 HP	potenza richiesta 33 kW - 45 CV required power 33 kW - 45 HP
	ATOMIZZATORE SPRAYER	potenza assorbita 13 kW - 18 CV absorbed power 13 kW - 18 HP	potenza assorbita 17 kW - 23 CV absorbed power 17 kW - 23 HP
	VENTOLA FAN	radiale in acciaio chiusa D.450 mm 4000 giri/min. portata aria: 4000 m³/h - velocità aria: 228 m/s	radiale in acciaio chiusa 450 mm 4500 giri/min. portata aria: 5400 m³/h - velocità aria: 188 m/s
	POMPA PUMP	centrifuga di alimentazione e agitazione CIMA CD 32 - 4000 giri/min. portata 120 l/min. - pressione massima 4,5 kg/cm²	centrifuga di alimentazione e agitazione CIMA CD 32 - 4250 giri/min. portata 140 l/min. - pressione massima 4,5 kg/cm²

Valori suscettibili di variazioni in funzione del dispositivo di distribuzione utilizzato
Values can vary according to the used distribution sprayhead

DIMENSIONI E PESO - DIMENSIONS AND WEIGHT

	New Plus 42-45		New Plus Gold 42-45	
	I. 300	I. 400	I. 300	I. 400
	LUNGHEZZA LENGTH	144-162 cm	144-162 cm	144-162 cm
	LARGHEZZA WIDTH	96 cm	112 cm	96 cm
	ALTEZZA HEIGHT	119 cm	122 cm	127 cm
	PESO WEIGHT	42: 208 kg 45: 210 kg	42: 211 kg 45: 213 kg	42: 216 kg 45: 218 kg

Il peso indicato è calcolato a vuoto SENZA il dispositivo di distribuzione e SENZA gli accessori eventualmente installati.
I valori sono riportati a titolo indicativo e possono variare secondo la configurazione della macchina.
Weight empty without distribution device and installed accessories.
The value are indicative only, and may vary depending on the configuration of the machine.

Nei paesi dell'Unione Europea le nostre attrezzature sono conformi alla Direttiva Europea "Macchine"; negli altri paesi sono conformi alle norme di sicurezza in vigore in quei paesi.

Within the European Union countries our equipments are in accordance with the "Machines" European Directive; in other countries they comply with safety regulations in force in those specific countries.



RIVENDITORE AUTORIZZATO - DEALER

Loc. Molino Quaroni n.7, Montù Beccaria - PV - (ITALY)
Tel. +39.0385.246636 - www.cima.it



cima[®]
ATOMIZZATORI-IMPOLVERATORI

New Plus 42-45



ATOMIZZATORI PNEUMATICI A BASSO VOLUME
PNEUMATIC LOW VOLUME SPRAYERS

Atomizzatori - Sprayers



- ★ Ampia scelta di testate di distribuzione, tutte dotate del nuovo sistema anti-sgocciamento (brev. N° 1745689) e di dispositivi di diffusione (mani e/o cannoni) di diverse dimensioni, adattabili in altezza, orientabili ed intercambiabili per garantire, su tutte le tipologie di colture, un'eccellente copertura e penetrazione nella vegetazione.



- ★ Broad range of sprayheads, all equipped with the new anti-drip system (patent Nr. 1745689). Sprayheads' distribution devices (hands or cannons) are available in different sizes and heights, they can be adjustable and interchangeable to guarantee a better spray penetration through the canopy and a complete coverage on any type of crop.



- ★ Regolatori a disco rotante con 15 fori calibrati (brev. N° 23238), sostituiscono il sistema a pastiglie. Erogazione da 70 a 3400 litri/ora.
- ★ Rotating calibration discs, 15 positions (patent Nr. 23238), very easy to adjust: delivery from 70 to 3400 l/h



- ★ Serbatoio in polietilene rotazionale, apertura di riempimento di grandi dimensioni (ø360) con coperchio a cerniera, indicatore di livello.

- ★ Serbatoio lavamani integrato I.15.
- ★ Serbatoio lavaimpianto integrato nel serbatoio principale (versioni GOLD).

- ★ Idromiscelatore integrato nel filtro a tazza.

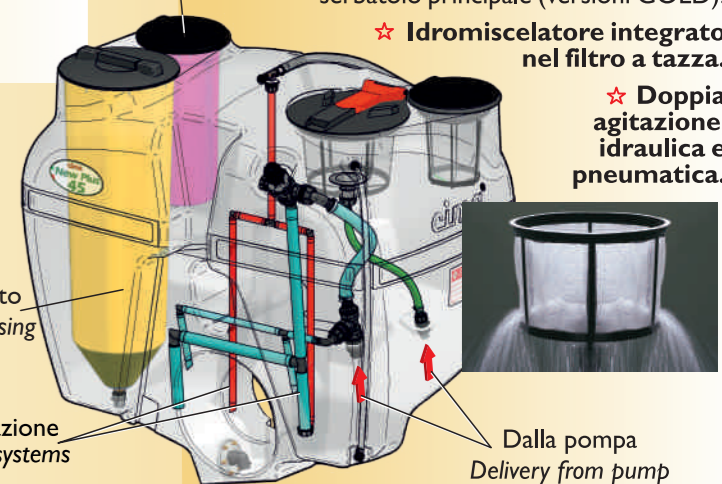

- ★ Trasmissione a cinghia poly-V che assorbe le sollecitazioni. Funzionamento per oltre 5000 ore. Il tenditore automatico evita lo slittamento e quindi l'usura. La qualità della polverizzazione resta inalterata nel tempo.
- ★ Ruota libera di sicurezza per arresto improvviso.



- ★ Poly-V belt drive, to absorb any stress. Long life belt - over 5000 hours. The automatic tensioner keeps tension constant on the belt, avoiding slipping and wear. High quality spray atomization after several years of use.

- ★ Overrunning clutch - Safety stop device in the event the PTO is suddenly stopped.

- ★ Polyethylene tank. Large filling opening (ø360) with hinged lid and graduated level indicator.
- ★ 15 litres fresh water tank included.
- ★ Spray-line rinsing tank integrated into the main tank (GOLD models).
- ★ Hydraulic pre-mixer incorporated within the basket filter.
- ★ Two agitation systems, liquid and air.

TESTATE - DISTRIBUTION HEADS

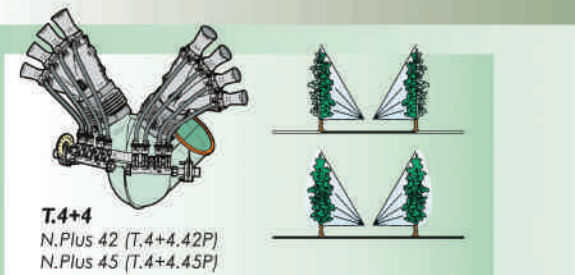

T.4+4
N.Plus 42 (T.4+4.42P)
N.Plus 45 (T.4+4.45P)

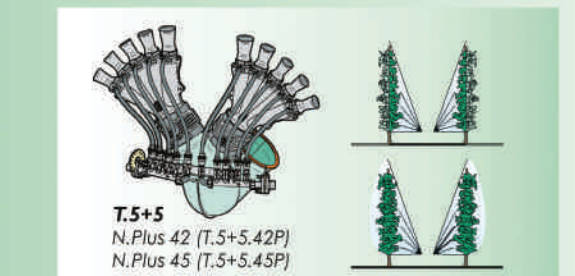

T.5+5
N.Plus 42 (T.5+5.42P)
N.Plus 45 (T.5+5.45P)

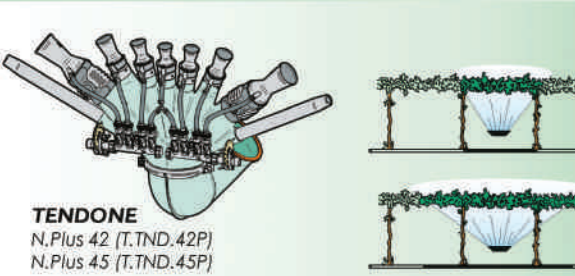

TENDONE
N.Plus 42 (T.TND.42P)
N.Plus 45 (T.TND.45P)

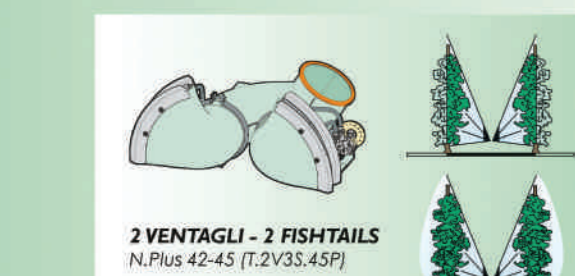

2 VENTAGLI - 2 FISHTAILS
N.Plus 42-45 (T.2V3S.45P)



STRASBURGO - STRASBOURG
N.Plus 42 (T.ST4.42P)
N.Plus 45 (T.ST4.45P)

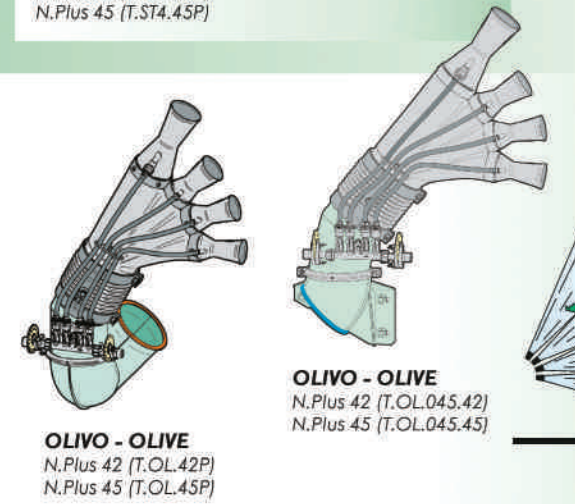

OLIVO - OLIVE
N.Plus 42 (T.OL.42P)
N.Plus 45 (T.OL.45P)

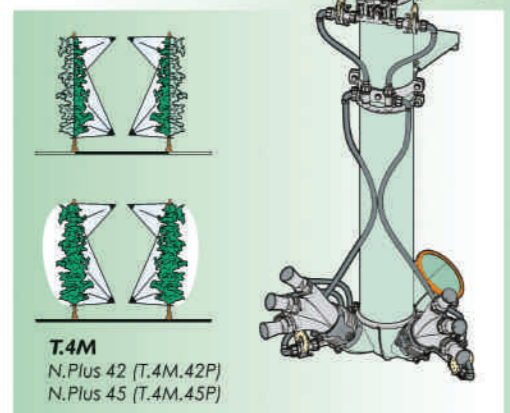
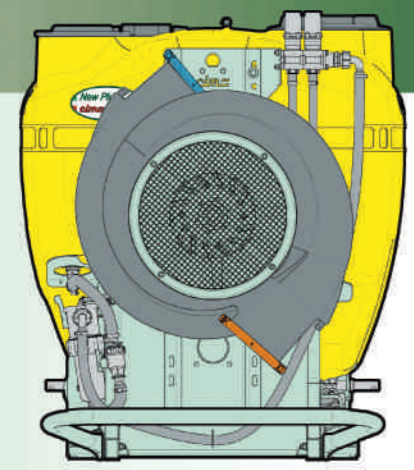

T.4M
N.Plus 42 (T.4M.42P)
N.Plus 45 (T.4M.45P)

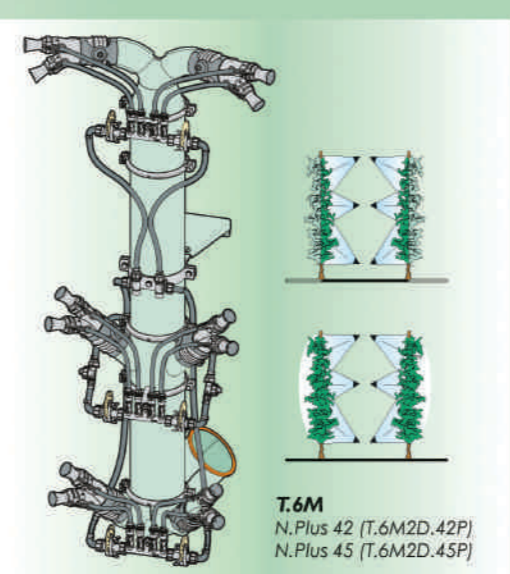

T.6M
N.Plus 42 (T.6M2D.42P)
N.Plus 45 (T.6M2D.45P)

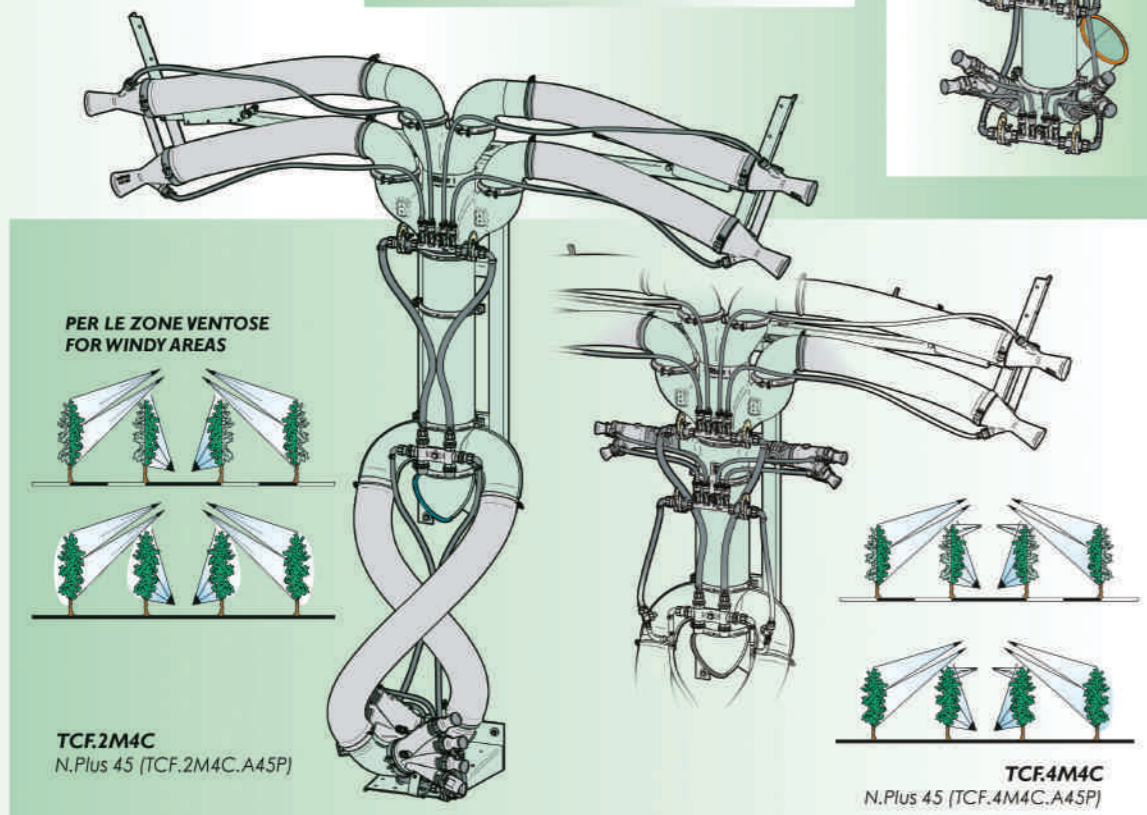

TCF2M4C
N.Plus 45 (TCF.2M4C.A45P)

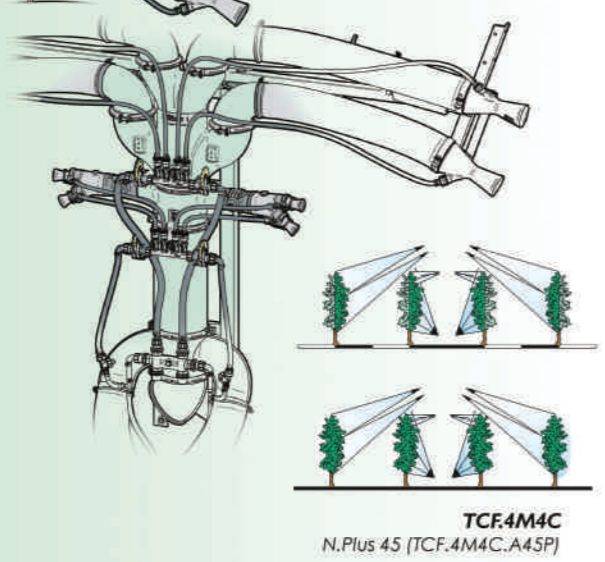

TCF4M4C
N.Plus 45 (TCF.4M4C.A45P)

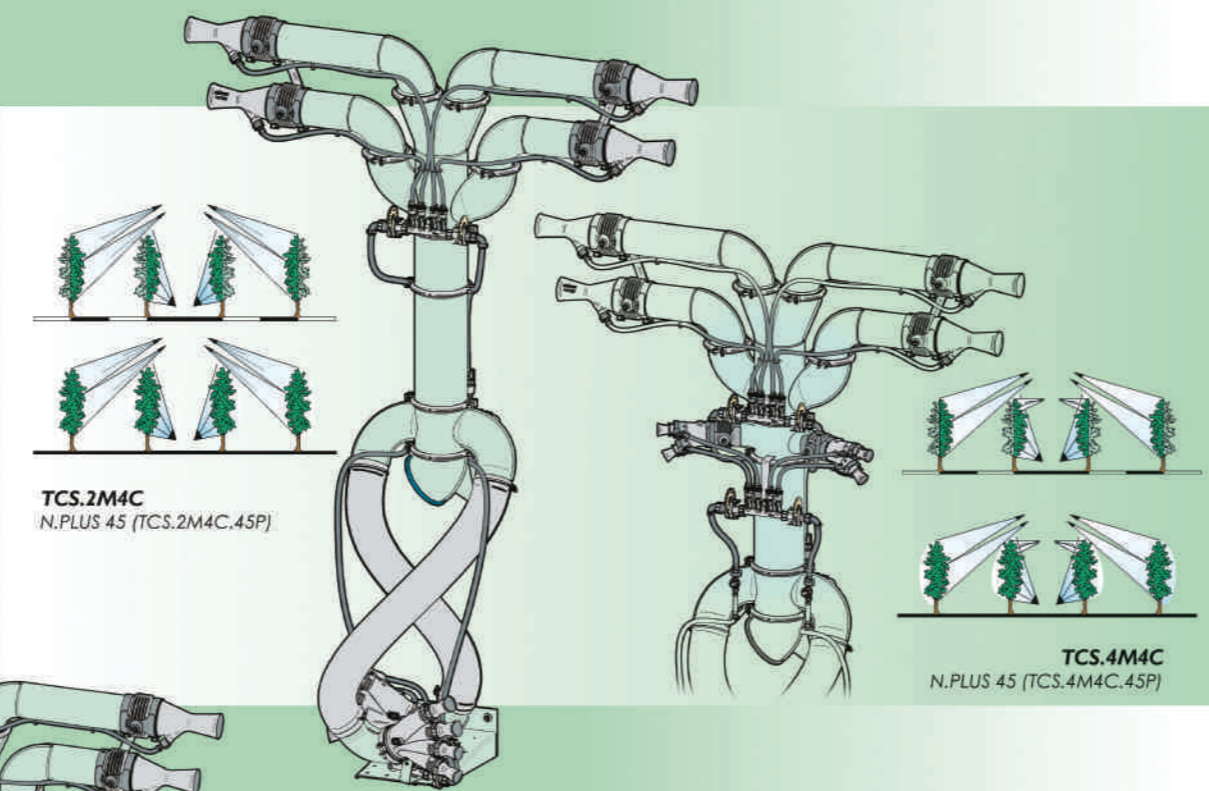

TCS.2M4C
N.Plus 45 (TCS.2M4C.45P)

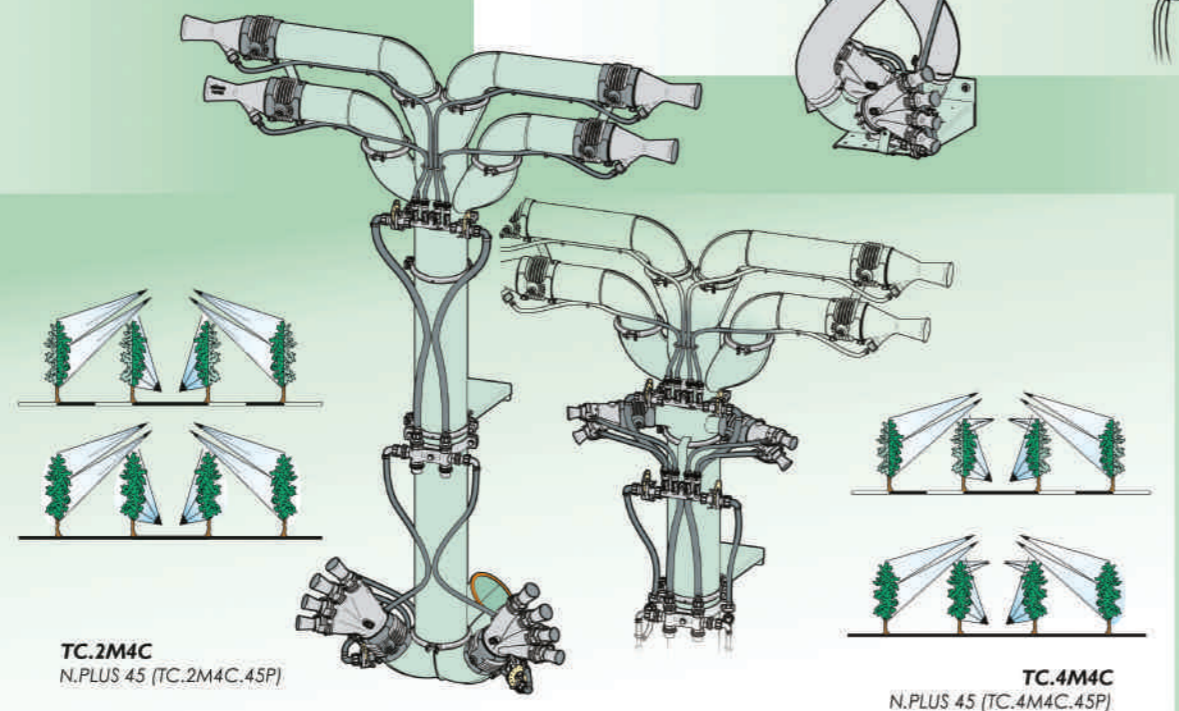

TC.2M4C
N.Plus 45 (TC.2M4C.45P)

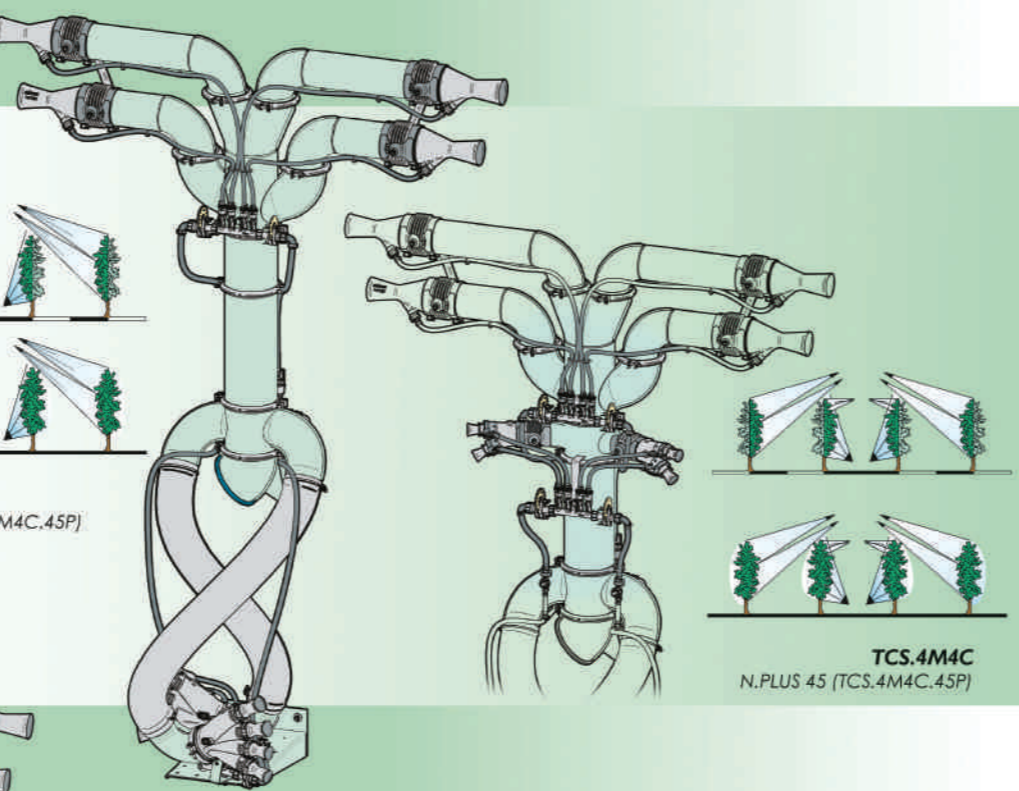

TCS.4M4C
N.Plus 45 (TCS.4M4C.45P)

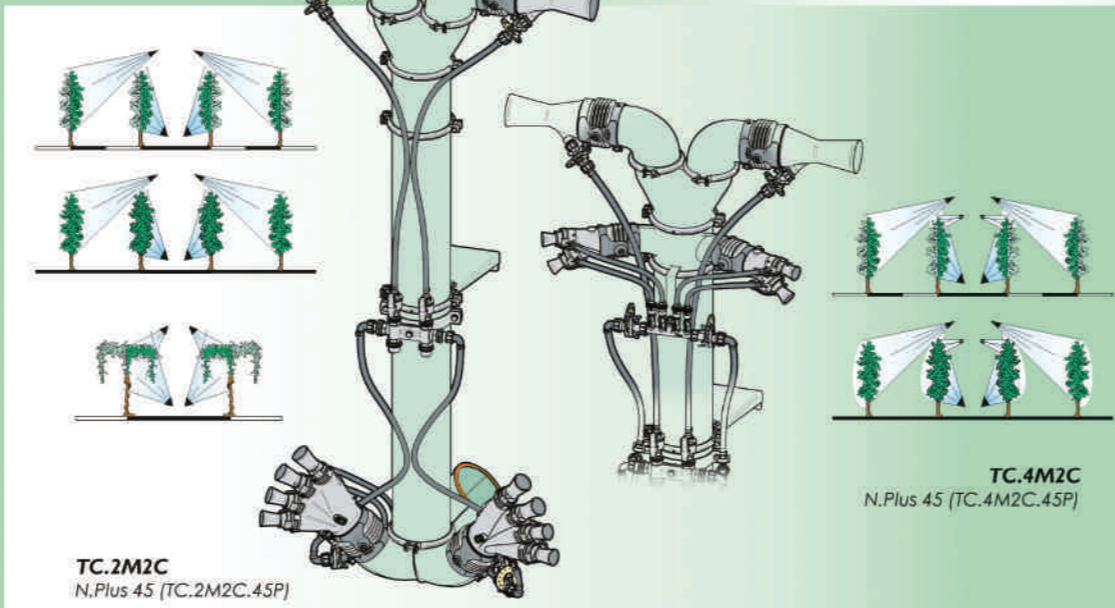

TC.2M2C
N.Plus 45 (TC.2M2C.45P)

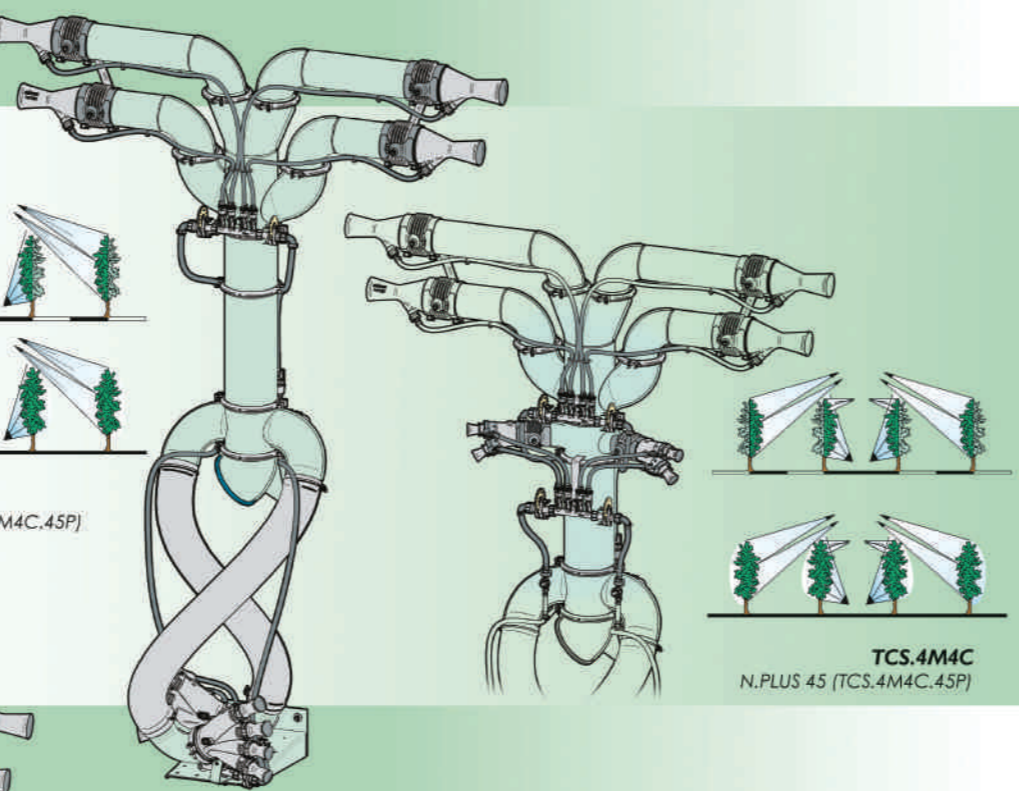

TC.4M2C
N.Plus 45 (TC.4M2C.45P)

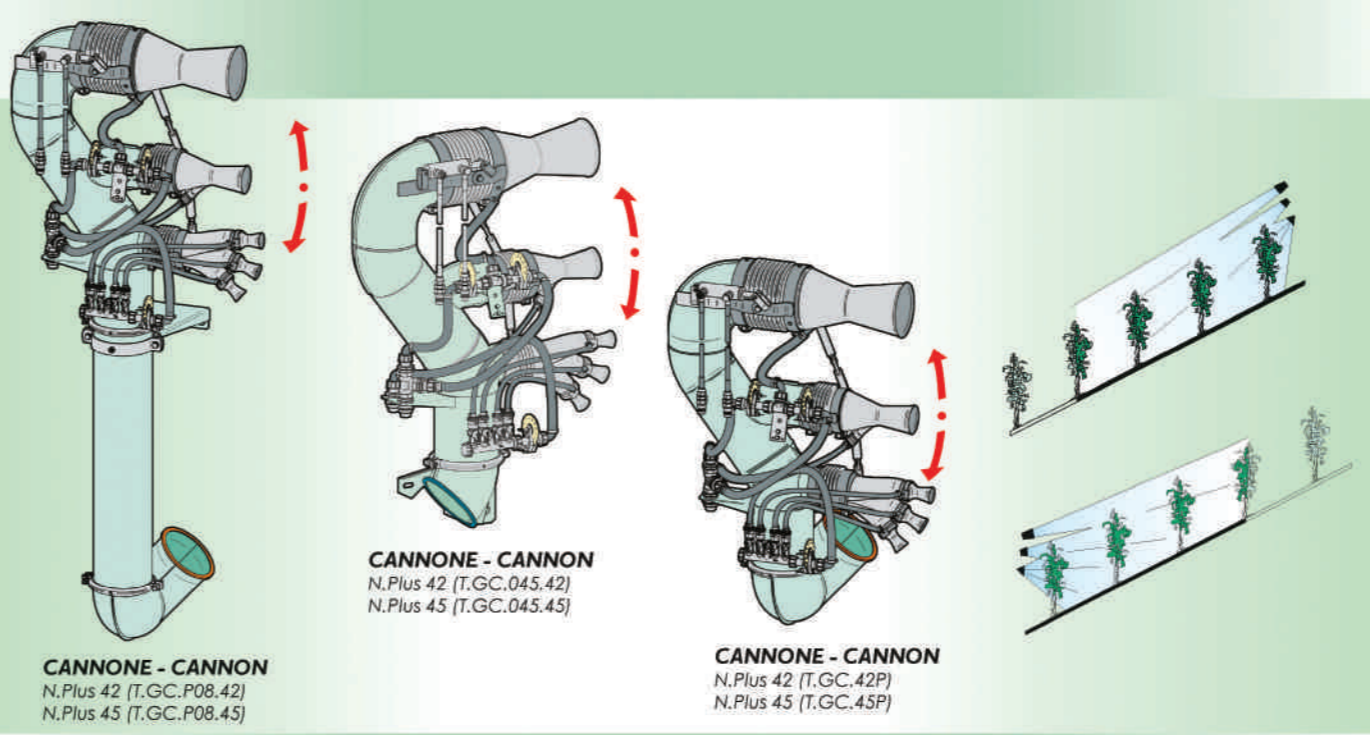

CANNONE - CANNON
N.Plus 42 (T.GC.P08.42)
N.Plus 45 (T.GC.P08.45)

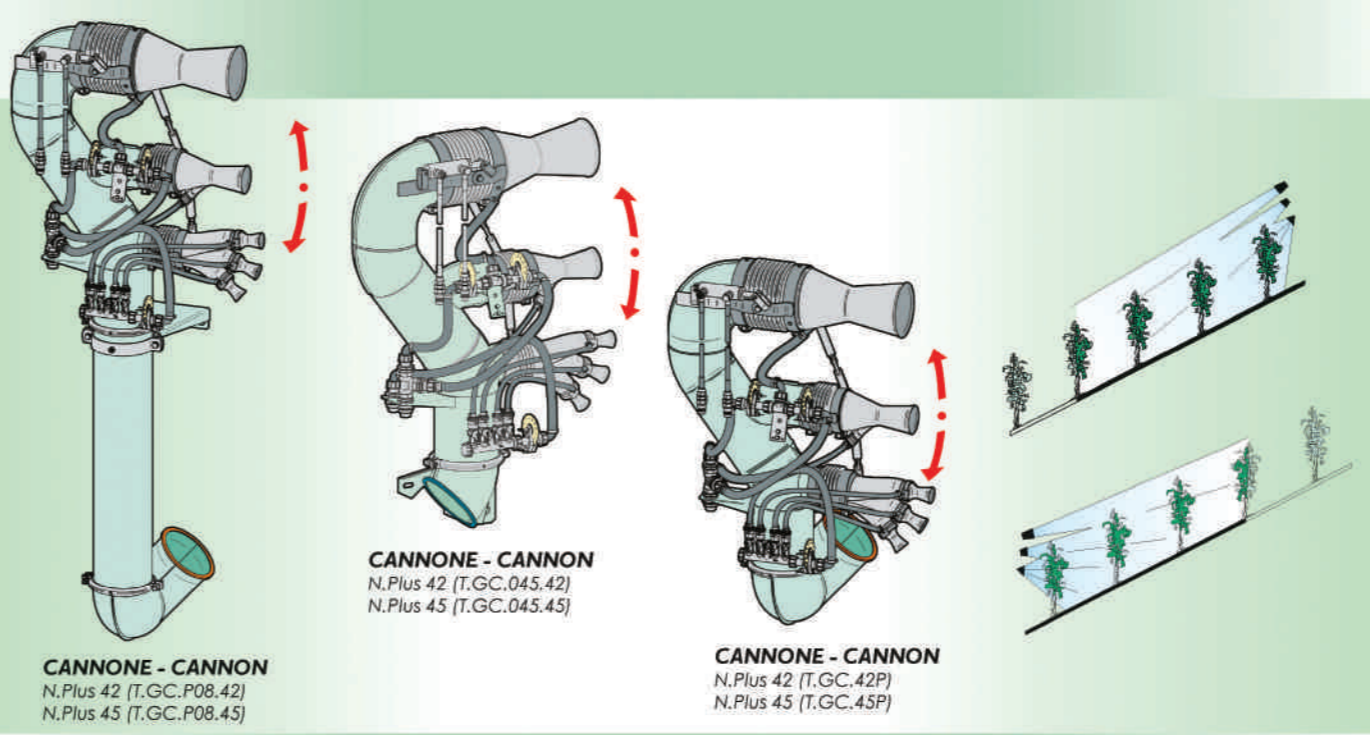

CANNONE - CANNON
N.Plus 42 (T.GC.42P)
N.Plus 45 (T.GC.45P)

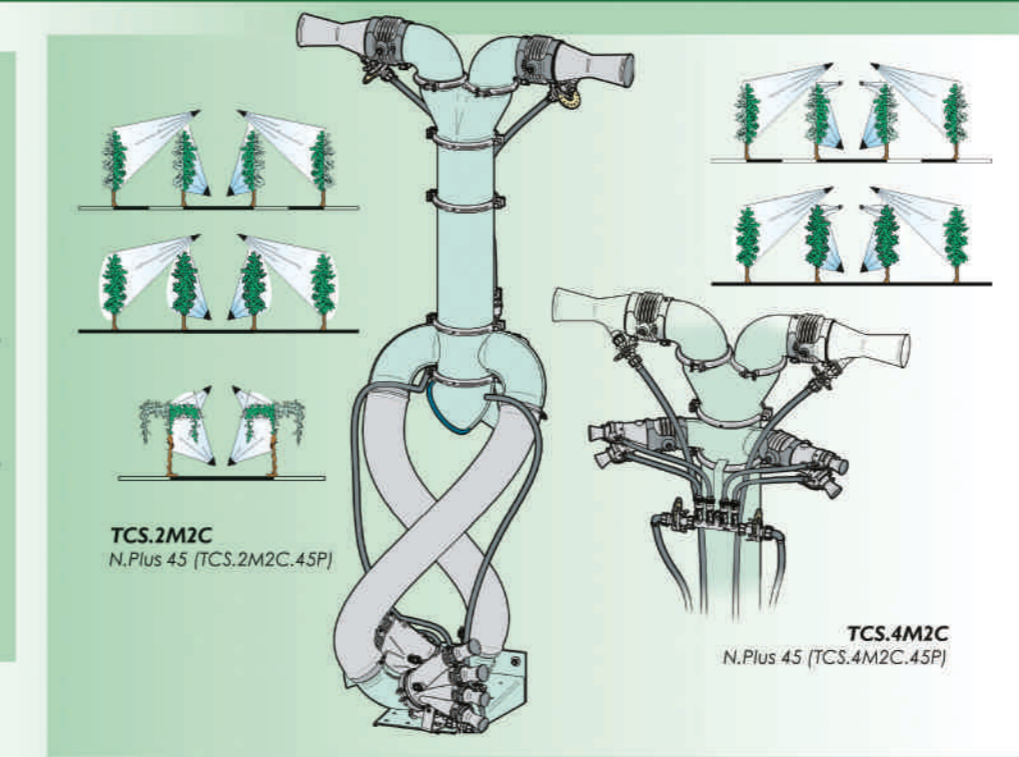

TCS.2M2C
N.Plus 45 (TCS.2M2C.45P)

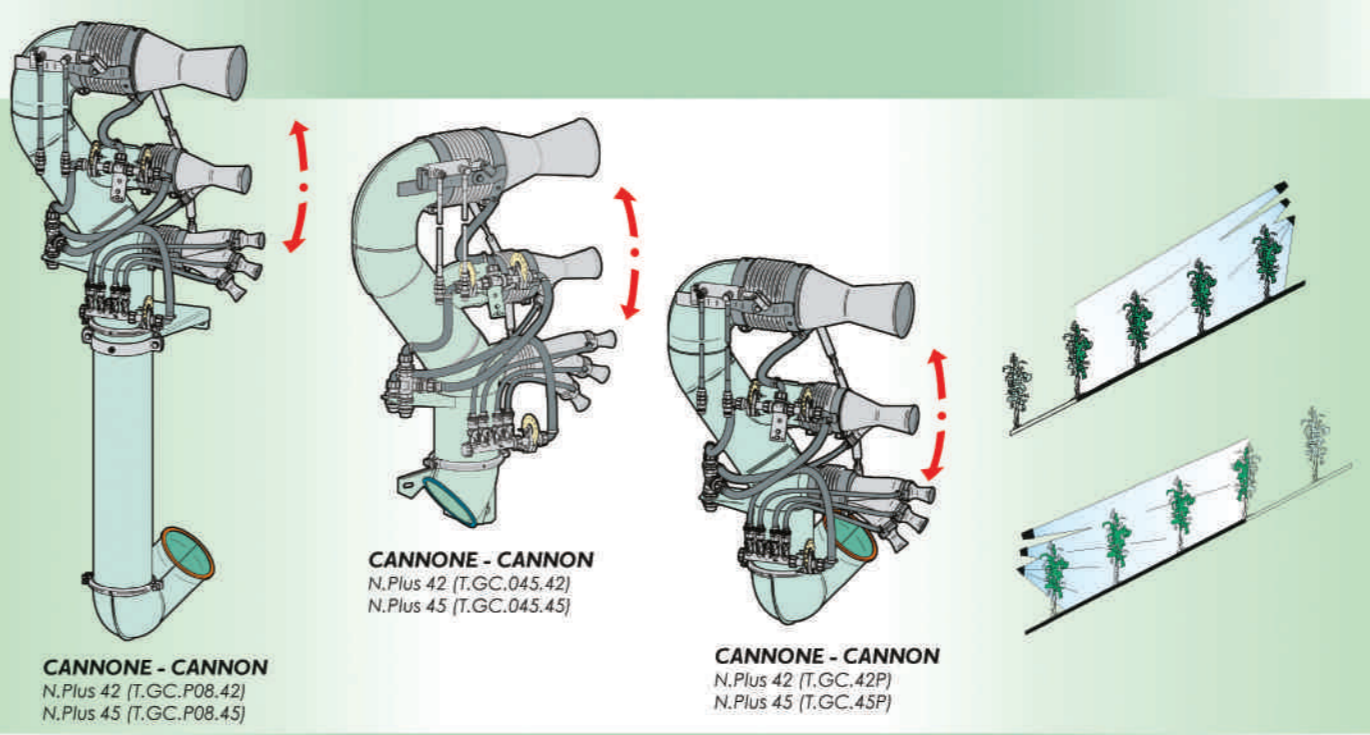

TCS.4M2C
N.Plus 45 (TCS.4M2C.45P)



CAFFÈ - COFFEE
Plus 45 (T.CA.45P)

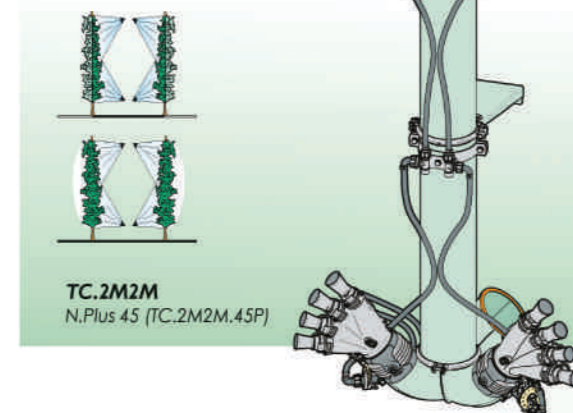

TC.2M2M
N.Plus 45 (TC.2M2M.45P)

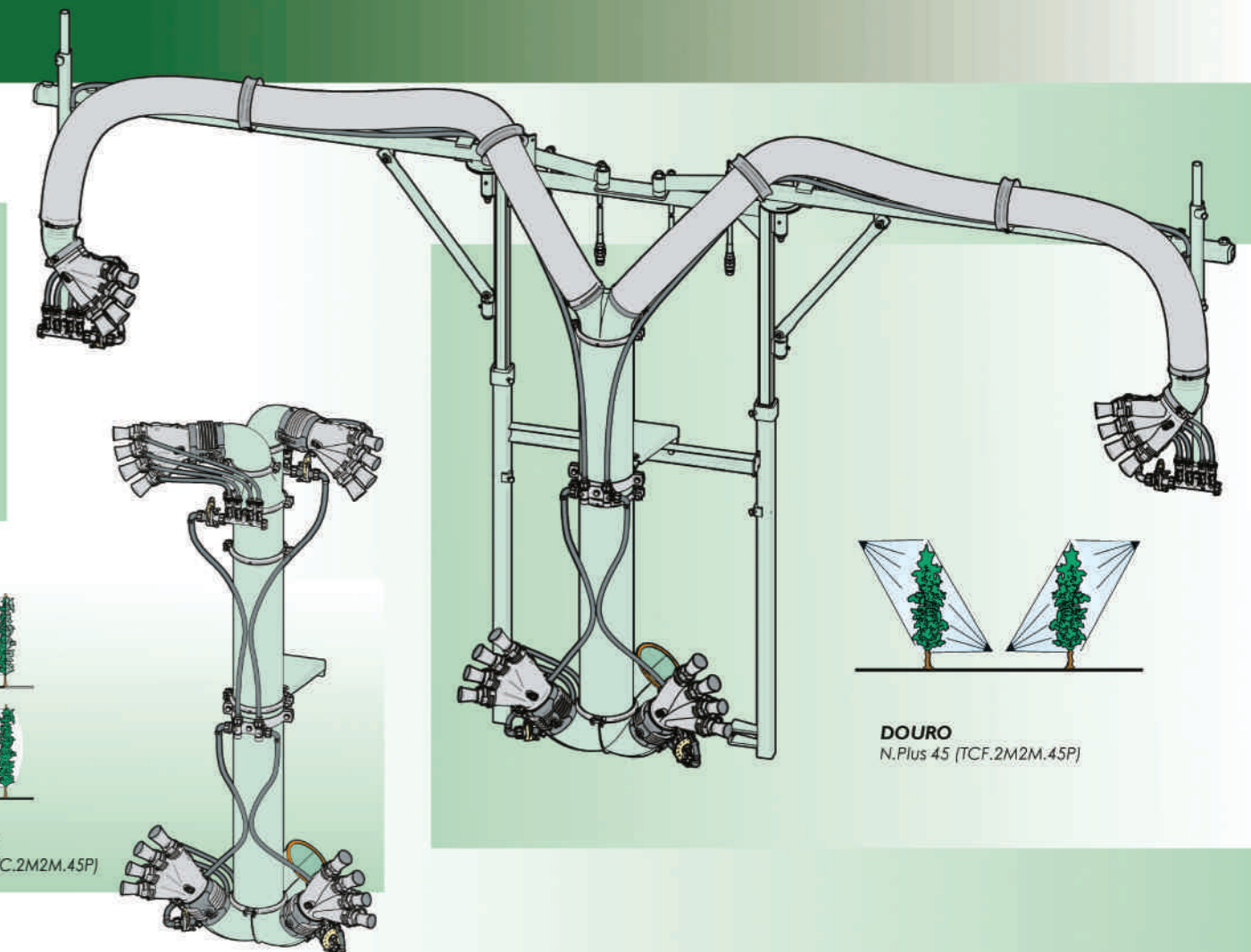

DOURO
N.Plus 45 (TCF.2M2M.45P)

ACCESSORI - OPTIONAL DEVICES

KIT PISTONI IDRAULICI HYDRAULIC-CYLINDER KIT

disponibile per:
available for:
T.4+4
T.5+5
T.O.L.

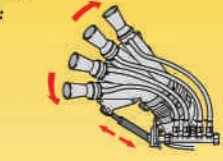

KIT PISTONI ELETTRICI (solo cannoni superiori) ELECTRO-CYLINDER KIT (only for upper cannons)



KIT IDRAULICO CHIUSURA BRACCI TCF TCF CLOSING HYDRAULIC KIT



REGOLATORE ELETTRICO PRESSIONE PRESSURE CONTROL ELECTROVALVE



COPIA RUOTE CON MOZZI COUPLE OF WHEELS WITH HUBS

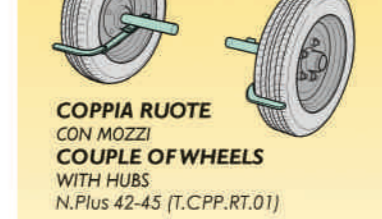

LAVABARATTOLI CONTAINER RINSING DEVICE (KIT.LAV.BOX)



E.P.A. 2.0 - Erogazione Proporzionale Avanzamento Delivery Proportional Advancement



GRUPPO 4 ELETTROVALVOLE 4 ELECTROVALVES CONTROL UNIT



CARDANO CARDAN SHAFT



COLLARE - COLLAR



TUBAZIONE RIEMPIMENTO FILLING PIPE



GIREVOLE IDRAULICO HYDRAULIC SWIVELLING DEVICE



Alcuni accessori sono forniti di serie in certi paesi - Some options are standard supplied in some countries

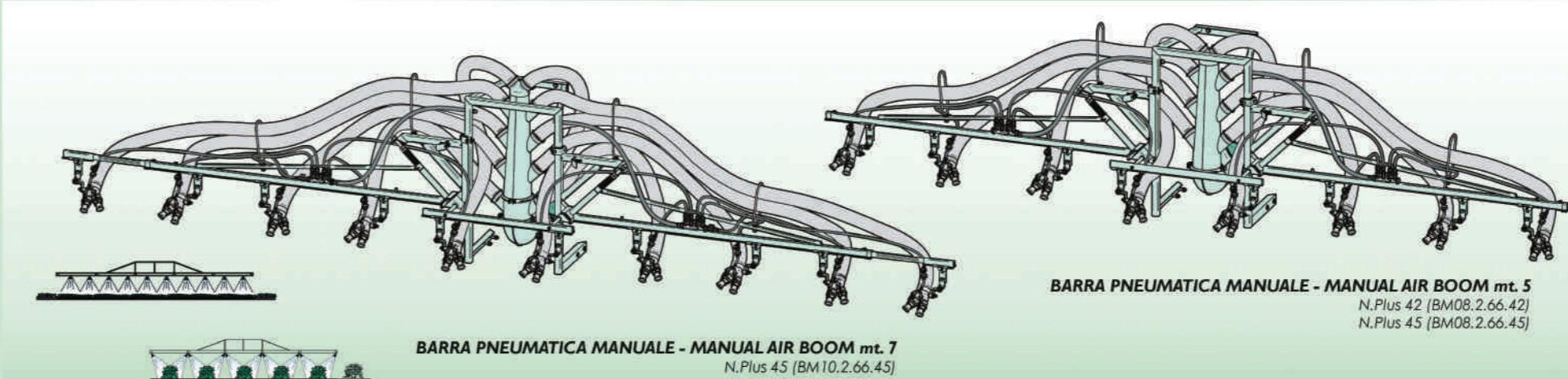

BARRA PNEUMATICA MANUALE - MANUAL AIR BOOM mt. 5
N.Plus 42 (BM08.2.66.42)
N.Plus 45 (BM08.2.66.45)

BARRA PNEUMATICA MANUALE - MANUAL AIR BOOM mt. 7
N.Plus 45 (BM10.2.66.45)